



What you'll be able to do.

- [Prepare to work in Design Space®.](#)
- [Navigate the Home Tab.](#)
- [Orient yourself to the Canvas.](#)
- [Begin your design with the Design Panel.](#)
- [Modify your designs with the Edit Bar on the Canvas.](#)
- [Manage images with the Layers Panel on the Canvas.](#)
- [Transition from design to cut on the Prepare Screen.](#)
- [Select your material on the Make Screen.](#)

Welcome to Cricut! Whether you bought a new machine, were gifted a bundle, or got a new addition to your Cricut collection, we are thrilled to welcome you to the Cricut Community!

In this course, we will go over the key points to know when using Design Space®, the free software needed to create with your Cricut machine. The information is in bite-size chunks so you can binge all of it or take it in a little at a time. Come back any time. This is all about what works best for you.

First, you'll need to download the Design Space app and create a Cricut ID. If you need help, here's a [step-by-step guide](#) to get started.

Let's begin at the top of the Design Space screen.

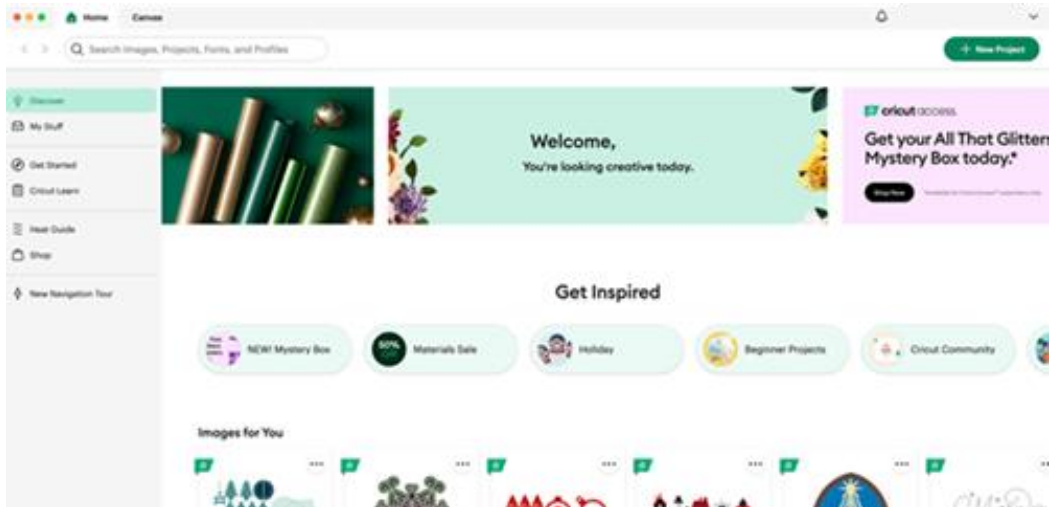

The Home Tab -

On the far left, is the **Home** tab. Here you will see the Universal Search Bar where you can explore projects, images, and profiles easily.

Below that, on the left-hand side, there is quick and easy access to helpful items.

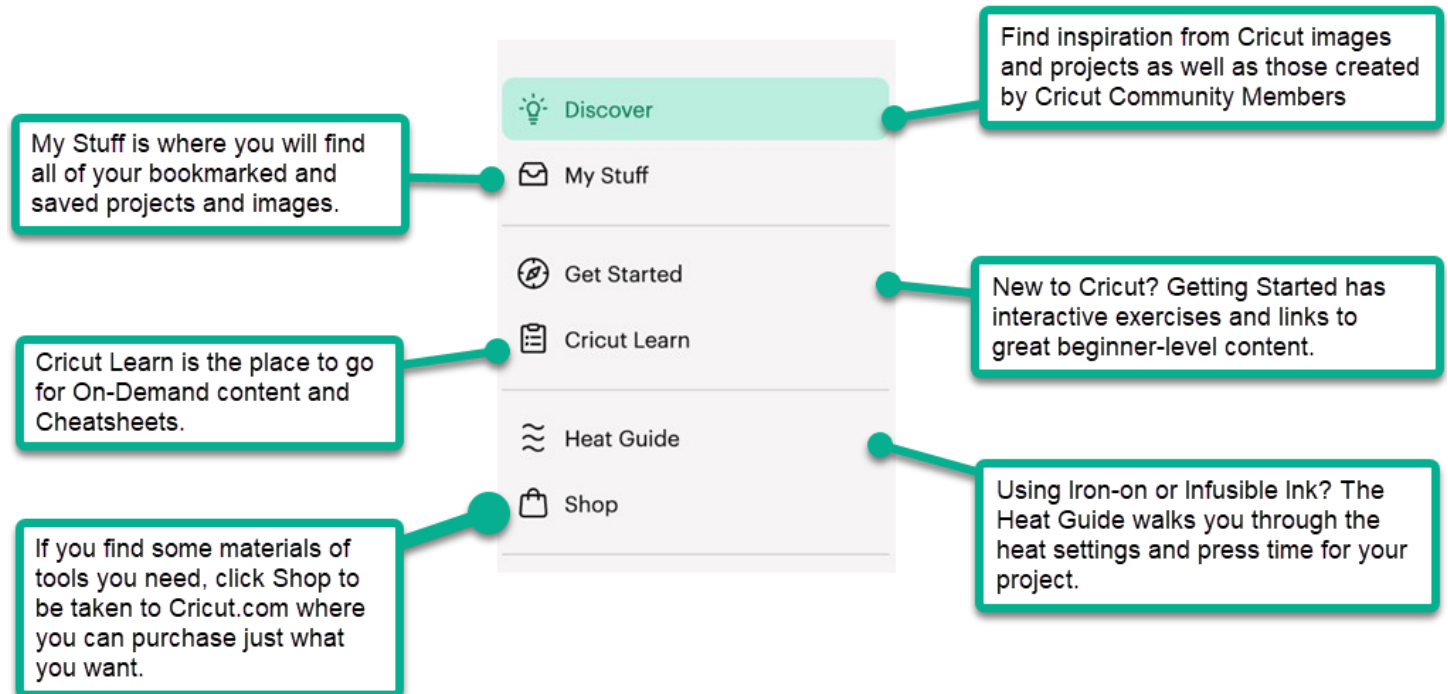

Click the down arrow next to your name in the top right corner. This is the **Avatar Menu**. Here you will find New Product Setup, Calibration, and all machine settings. This is your one-stop for all account and settings information.

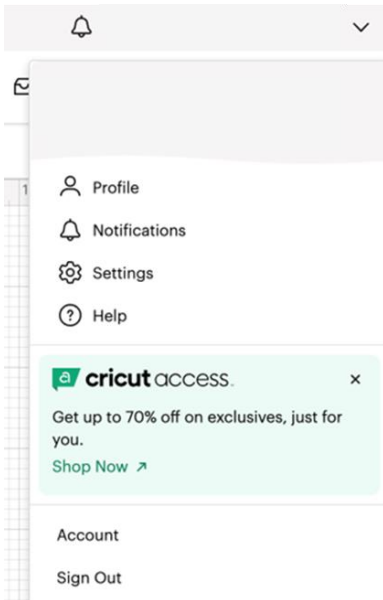

Profile: At the top, you'll see your profile, where you can add a little bit of information about yourself, a photo, and more. It isn't required but is a great way to connect with the Cricut Community.

Notifications: Click on the bell icon to see your notifications. You can adjust the notifications you receive in **Settings**.

Settings: Now you can access all your settings under one icon.

Click on **Settings** and explore the different tabs. (See descriptions below)

The **General** tab is where you can adjust your saving for offline, switch between live and beta, check your subscription status, and see your Design Space version. You can even check what is new since your last update.

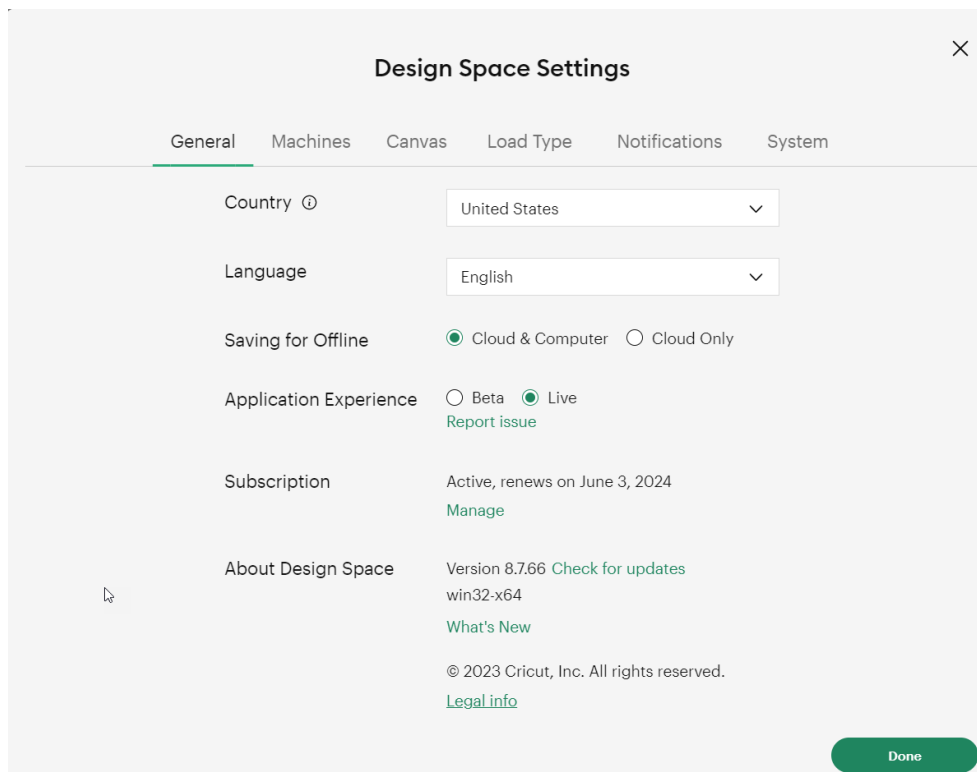

The **Machines** tab is where you will do all things related to your machine(s), from new product setup to updating firmware, calibrations, and more.

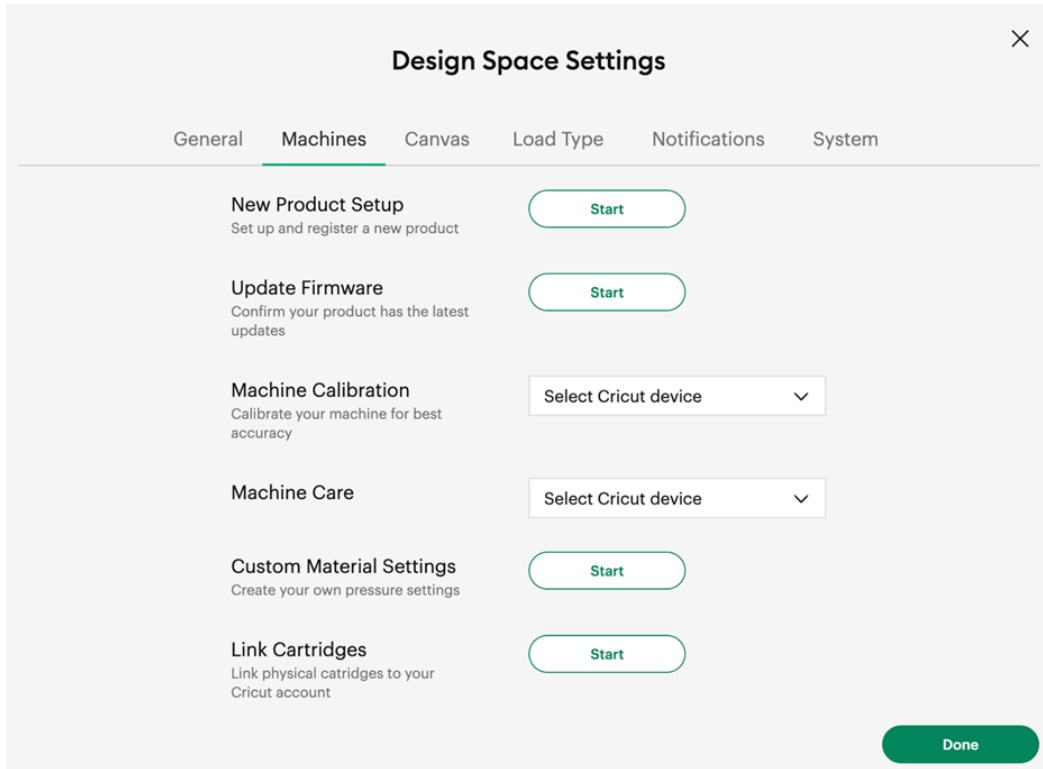

Next is the **Canvas Tab**. Here you can adjust the way your canvas looks. Do you want to see the grid? Do you want to see measurements represented in imperial (inches) or metric (centimeters)? You can also select if you want your operation type visible in your layers panel.

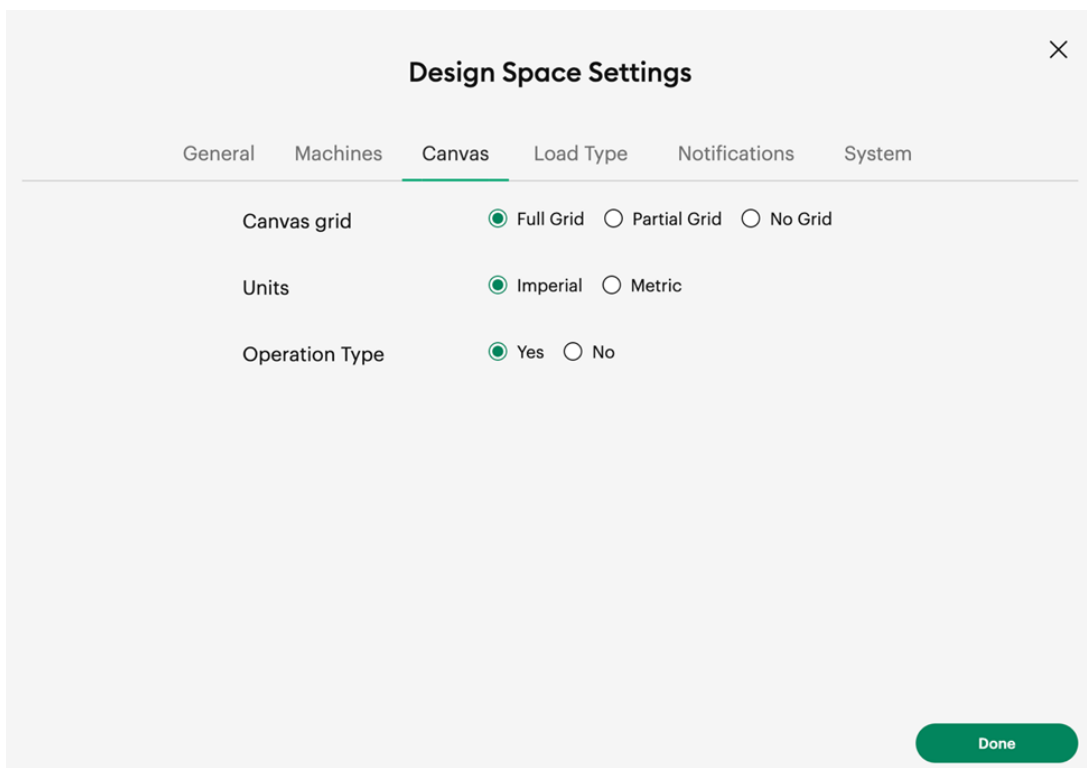

Load Type is helpful if you tend to use a specific material or size of mat. You can even have different defaults for each machine.

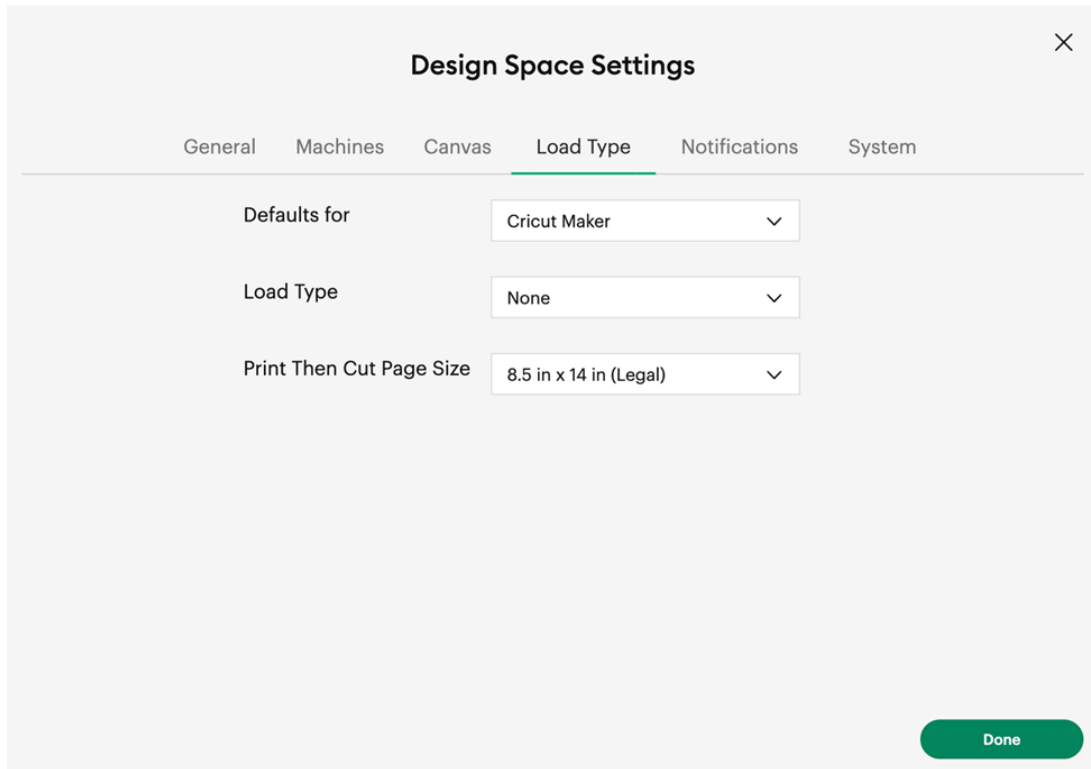

Next is the **Notifications** tab where you can select which notifications you want to receive.

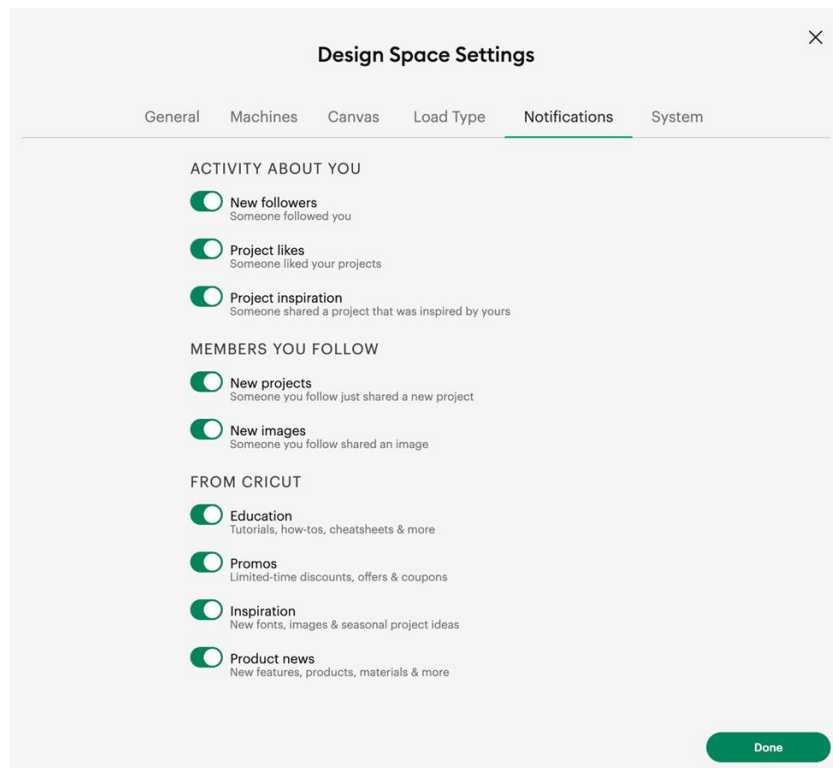

Finally, we have information on your **System**. You may be asked for this information if you call Member Care.

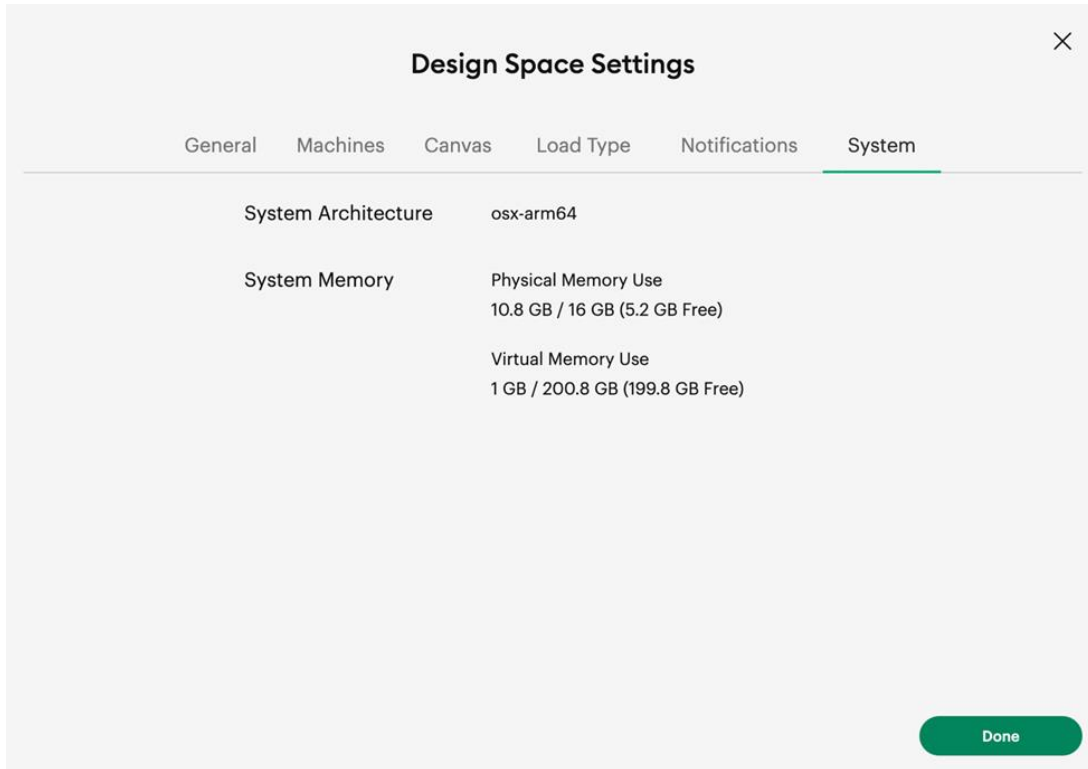

The screenshot shows the 'Design Space Settings' window with the 'System' tab selected. The settings are as follows:

Setting	Value
System Architecture	osx-arm64
System Memory	Physical Memory Use 10.8 GB / 16 GB (5.2 GB Free)
	Virtual Memory Use 1 GB / 200.8 GB (199.8 GB Free)

A 'Done' button is located at the bottom right of the settings window.

Below Settings, you can click on **Help** to search for help topics, get contact information for Member Care, or open a Chatbot.

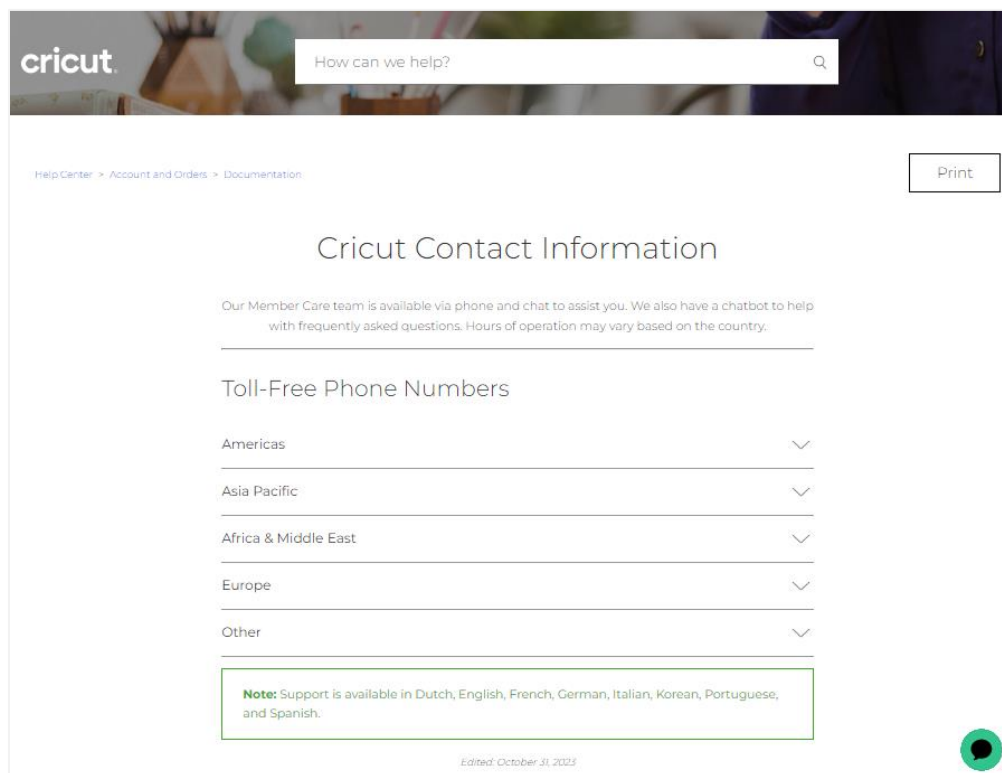

The screenshot shows the Cricut Help Center page for 'Cricut Contact Information'. At the top, there is a search bar with the text 'How can we help?' and a magnifying glass icon. Below the search bar, the breadcrumb trail reads 'Help Center > Account and Orders > Documentation'. A 'Print' button is located in the top right corner. The main heading is 'Cricut Contact Information'. Below this, a paragraph states: 'Our Member Care team is available via phone and chat to assist you. We also have a chatbot to help with frequently asked questions. Hours of operation may vary based on the country.' Underneath, there is a section titled 'Toll-Free Phone Numbers' with a list of regions, each with a dropdown arrow: Americas, Asia Pacific, Africa & Middle East, Europe, and Other. A green-bordered box contains a note: 'Note: Support is available in Dutch, English, French, German, Italian, Korean, Portuguese, and Spanish.' At the bottom center, it says 'Edited: October 31, 2023'. A green circular chatbot icon is in the bottom right corner.

Clicking **Account** will open a new browser tab with your basic account information. You may need to sign in using your Cricut ID to see your details since it includes payment information.

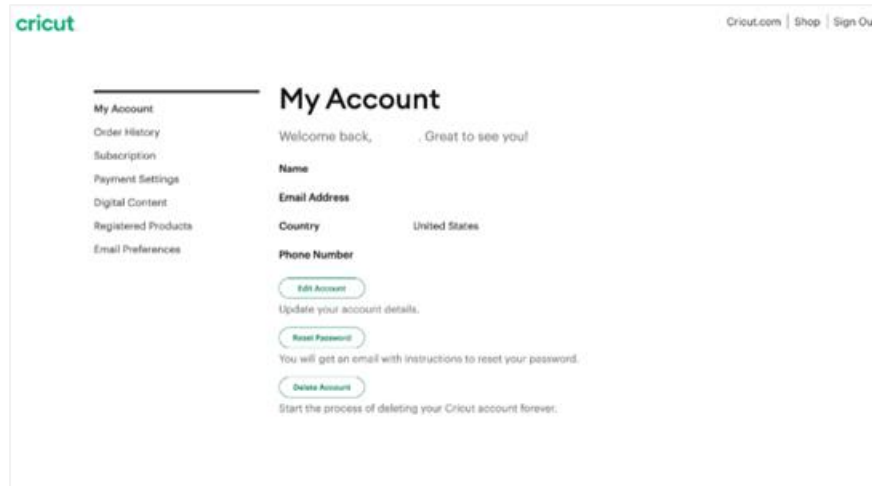

At the bottom of the Avatar Menu, you can **Sign Out**.

Next, we'll take a closer look at the **Canvas Tab**.

The Canvas Tab -

The Canvas Tab is where you get to create or customize your projects.

Access the Canvas Tab by clicking on it at the top of the Design Space Home Screen, by starting a new project, or by selecting Customize in a ready-to-make project.

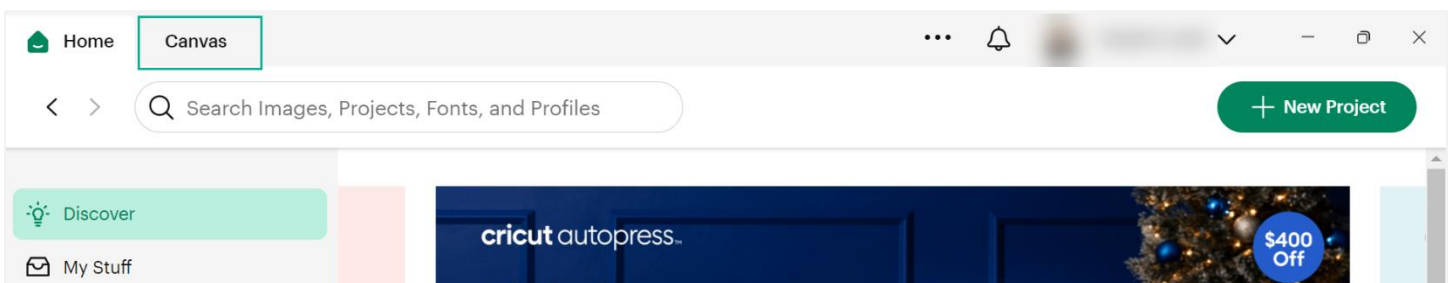

Let's begin with an orientation to the Canvas.

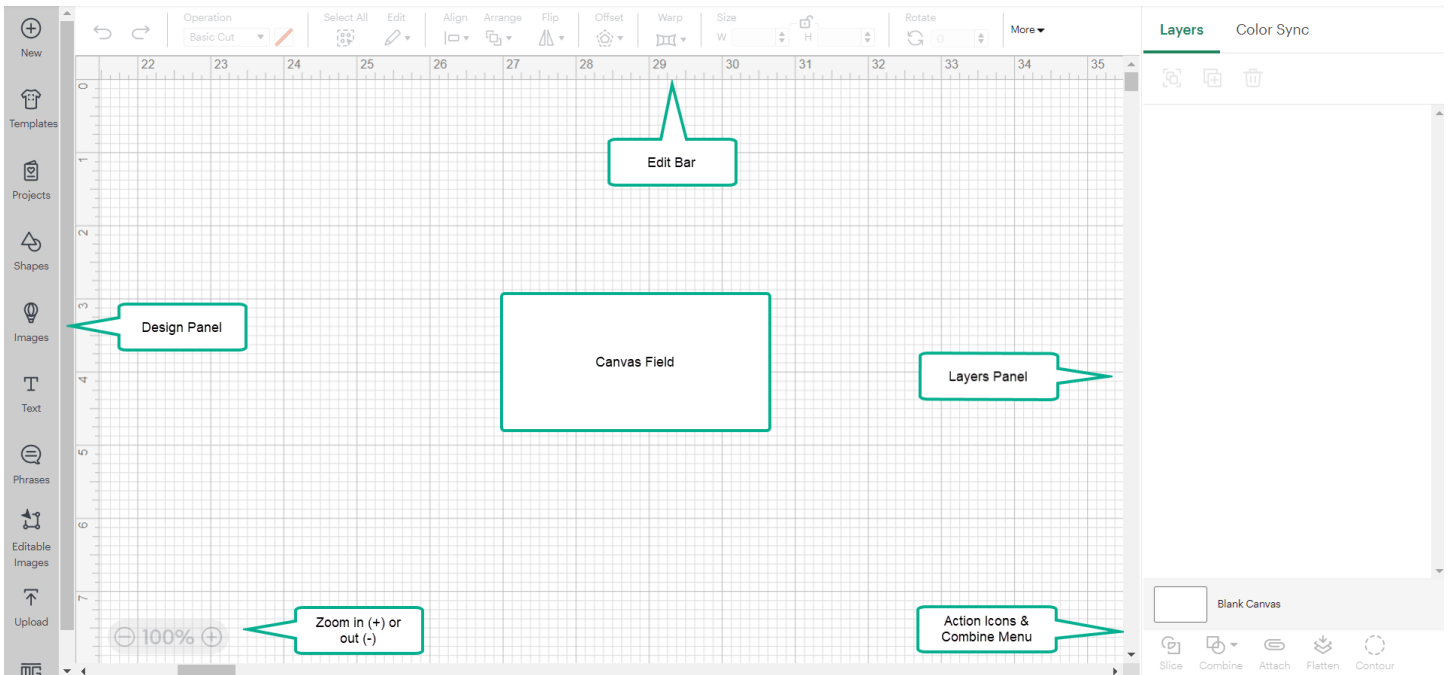

Once you are on the Canvas you can manipulate design elements, including images, text, and shapes to make your project.

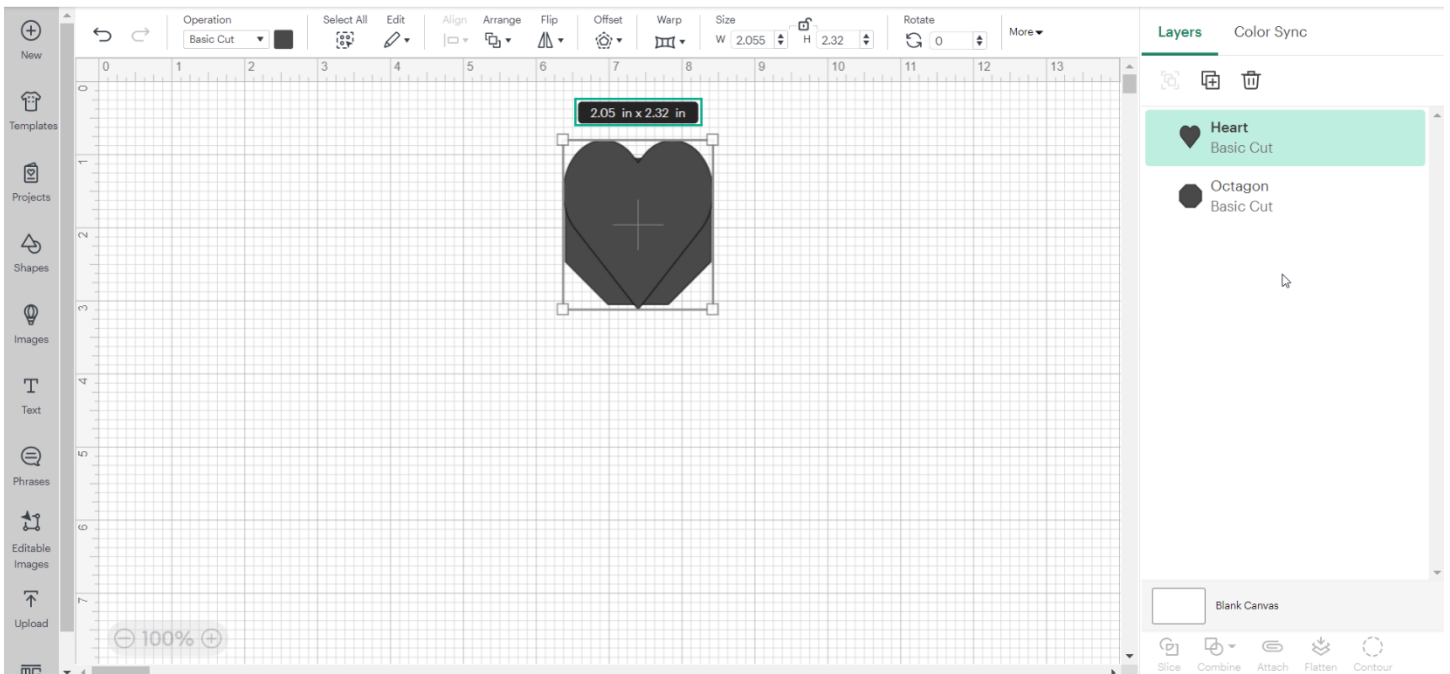

Use the plus or minus icons on the bottom left to zoom in and out of your canvas.

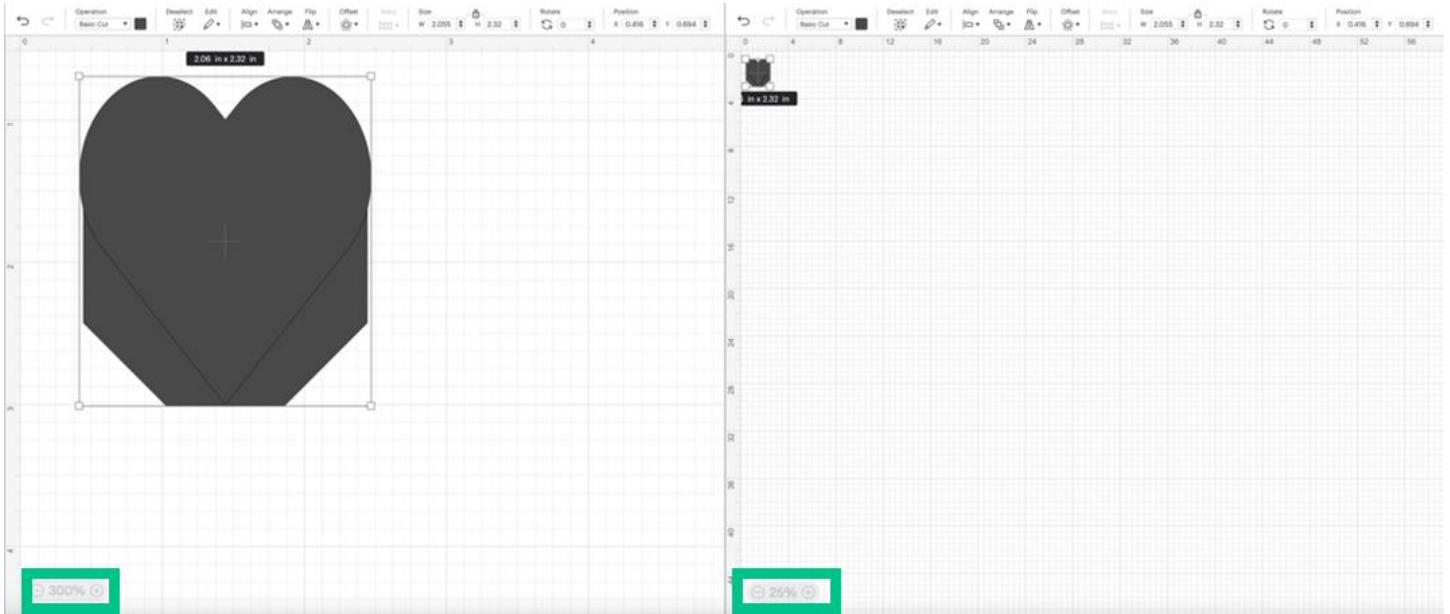

These guides show you the size of your design.

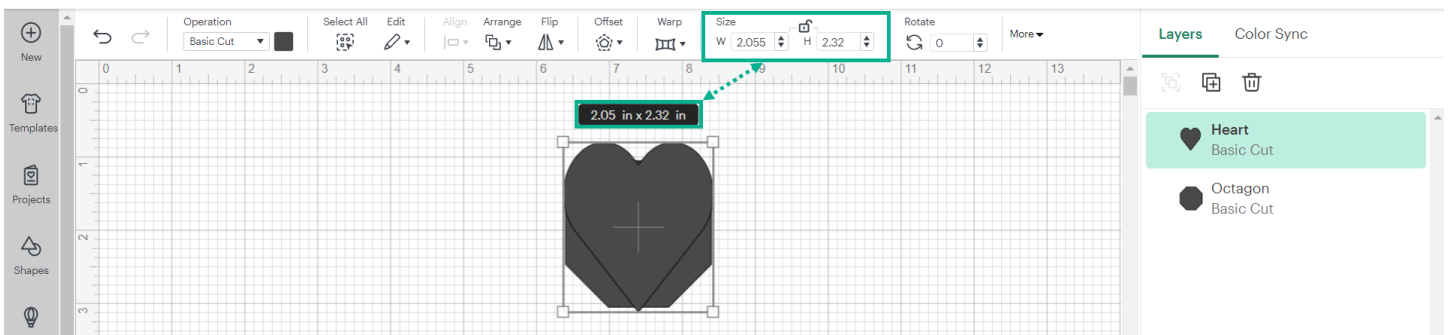

These handles allow you to move, rotate or resize your design elements.

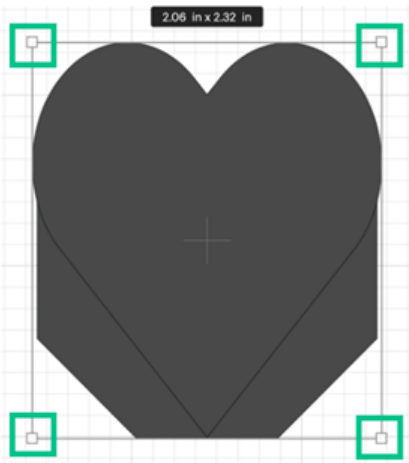

Edit Bar -

The Edit Bar at the top of the Canvas gives you many options for manipulating your design and will populate with different tools based on what you are working on.

When you are working with shapes, it will display options for sizing and modifying your design (operation type, image position, size, orientation, etc.).

When working with fonts, the options will reference the text (font selection, size, color, cut vs. draw, etc.).

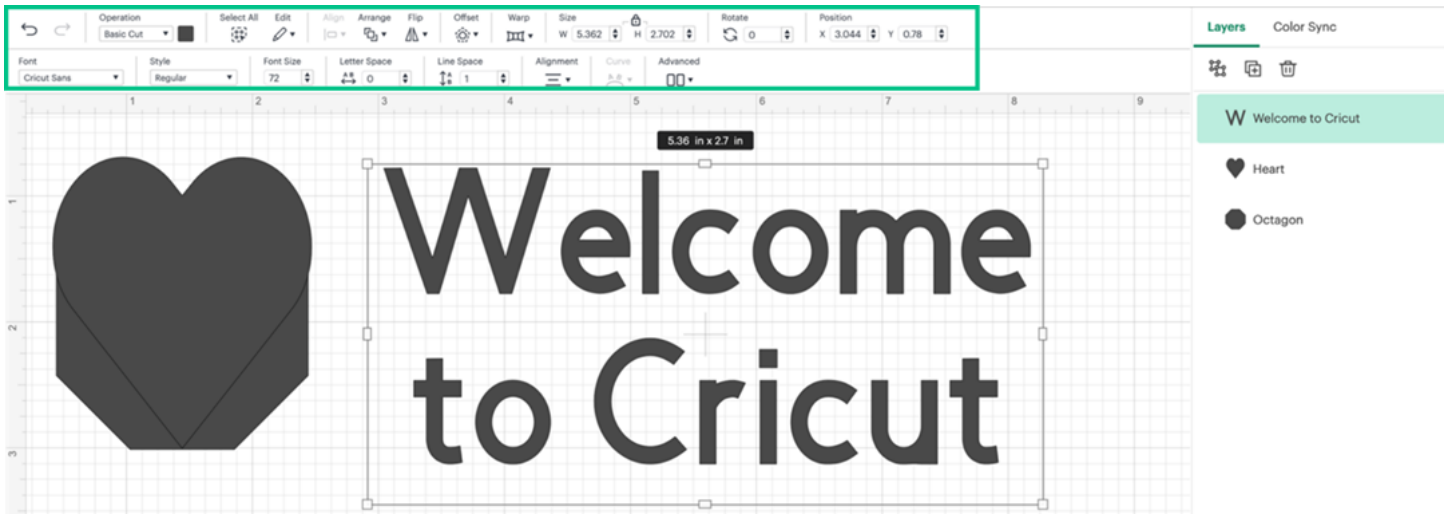

Layers Panel -

This is the layers panel, which displays each layer of the elements on your canvas.

You can group, duplicate, delete, combine, attach, flatten, contour, rename, or just hide from view each layer while designing.

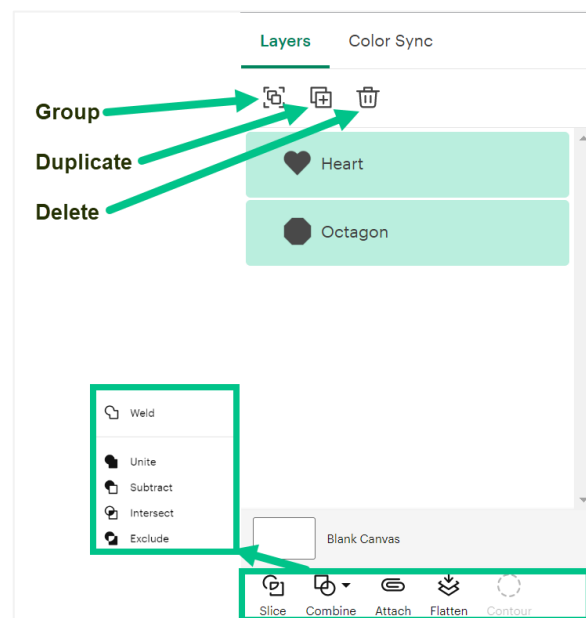

Next, we will look at the **Design Panel** in more detail.

The Design Panel -

On the left-hand side, you'll find the Design Panel where you can add things to your Canvas, including ready-to-make projects, shapes, thousands of images, text, and more.

You can even upload your own images! Let's go through each icon in more detail:

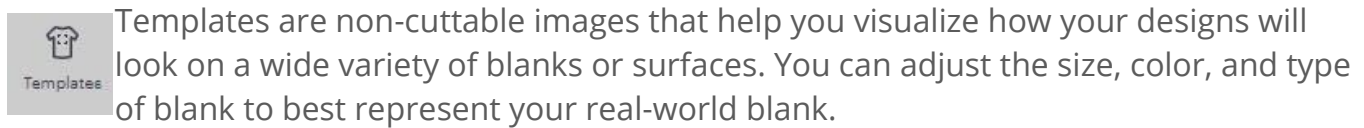
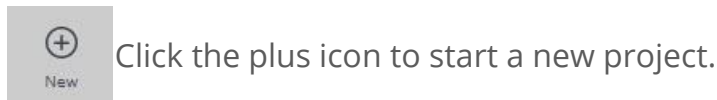

Projects is where you'll find ready-to-make designs, created by our design team, for a variety of occasions and applications. You can search by many different categories. Be aware that your machine selection may affect which projects display in your search results.

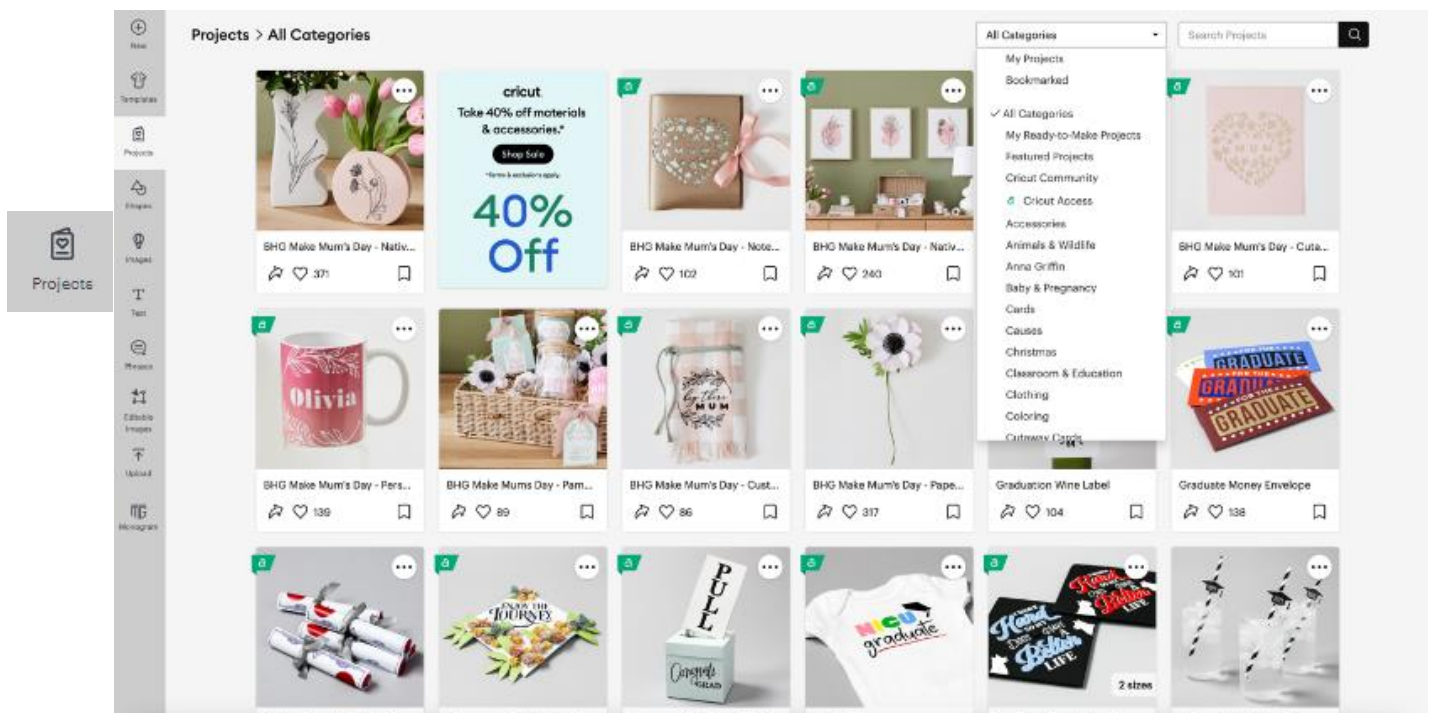

Shapes has a series of standard shapes. These can be useful as backgrounds or to build your own unique shapes.

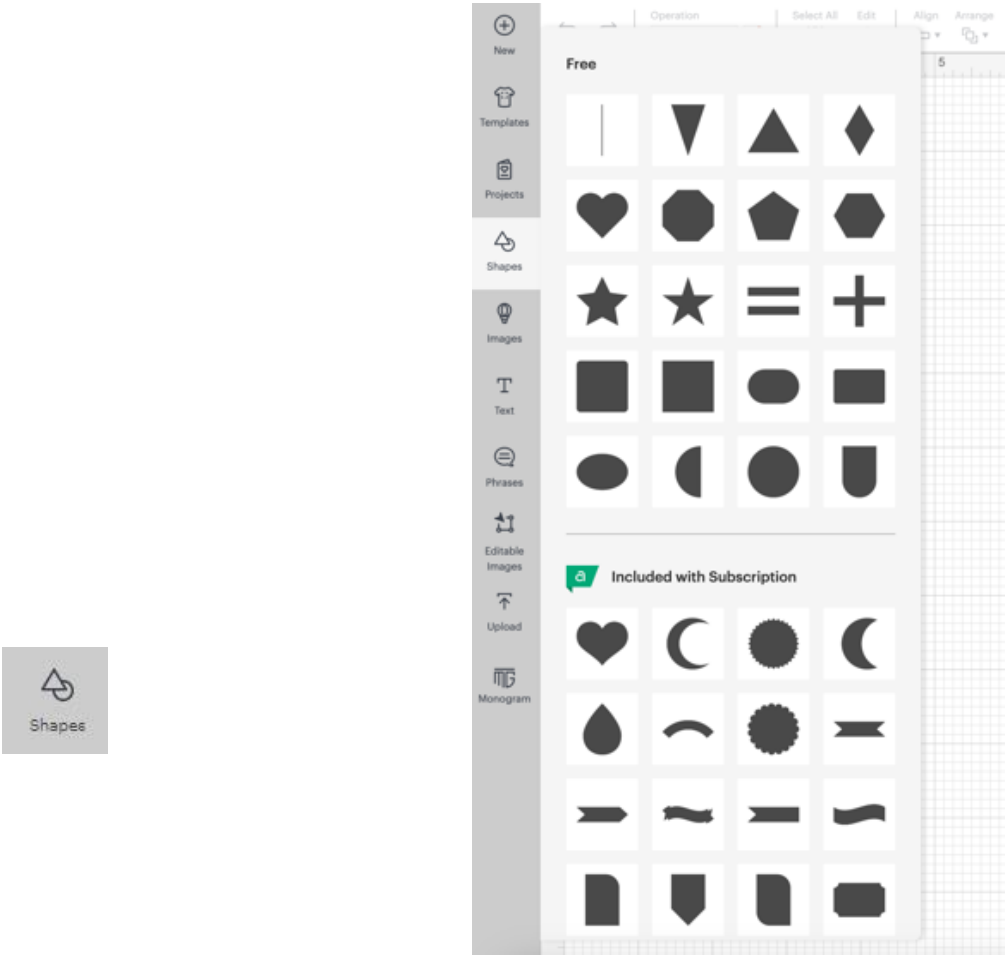

You can customize these shapes by adjusting their size and proportions by toggling the lock in the size panel of the Edit Bar. Change a square to a rectangle or a circle to an oval.

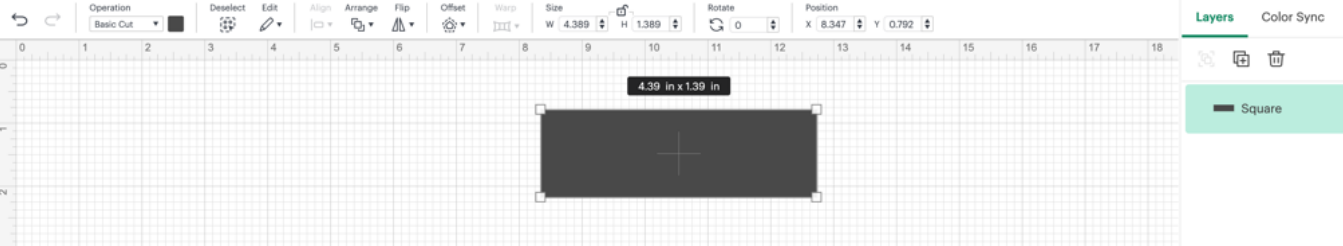

You can also combine multiple shapes using the Combine feature. Find more on the Combine feature and the Action Icons [here](#).

Images contain thousands of images that you can use to create your own designs. You can filter the images by lots of different criteria like complexity, material, creator, or layers.

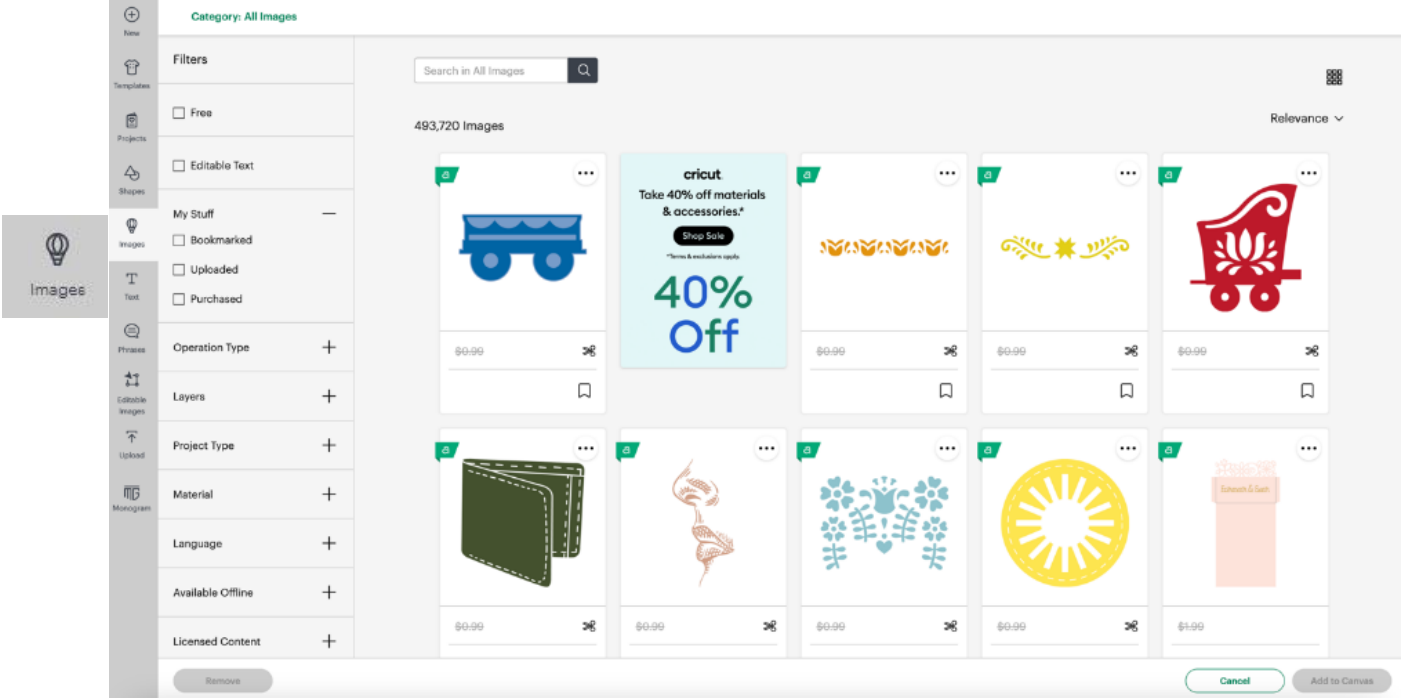

To add text to your Canvas, click the Text icon. Once you have your text on the Canvas, the text edit bar will activate. Here you can choose from hundreds of fonts and styles, use text tools like Warp, and more.

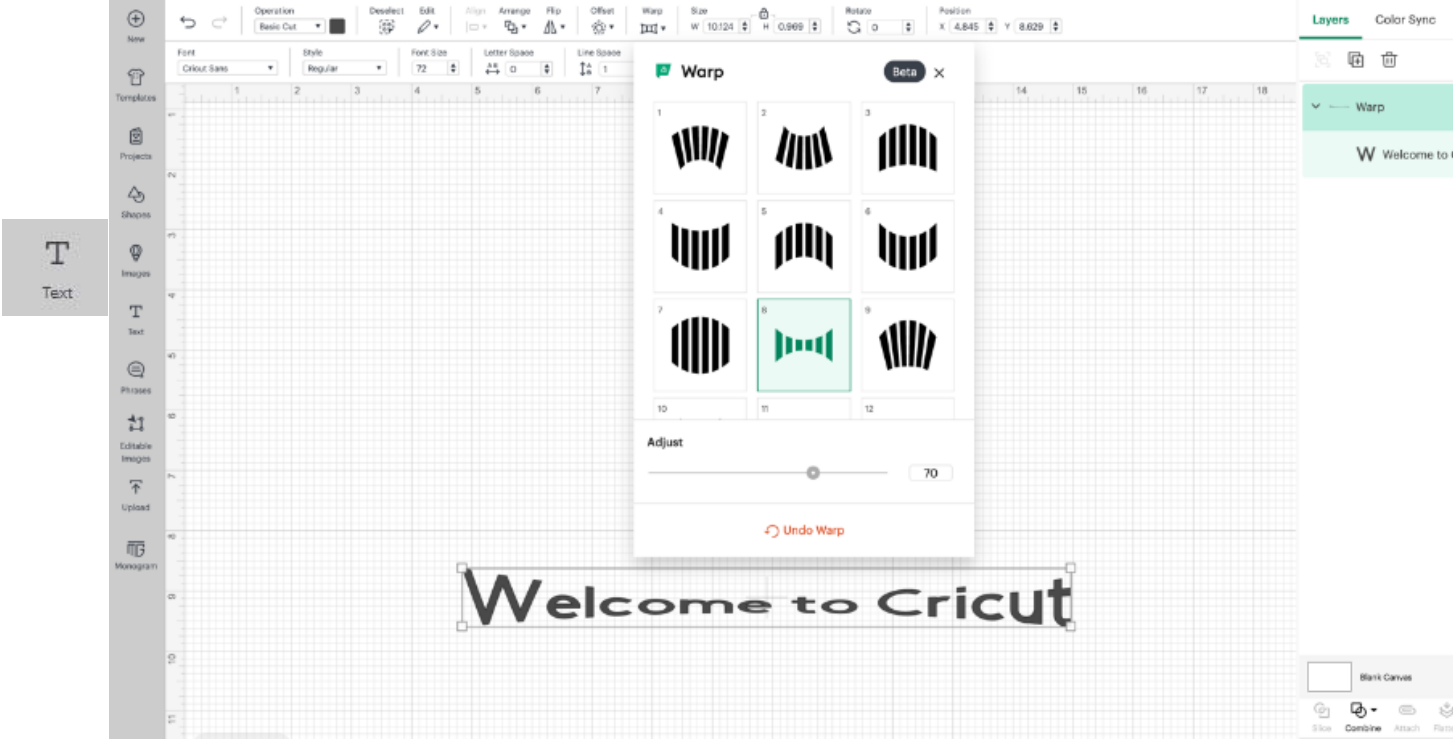

If you'd rather work with some pre-designed phrases instead, we've got you covered.

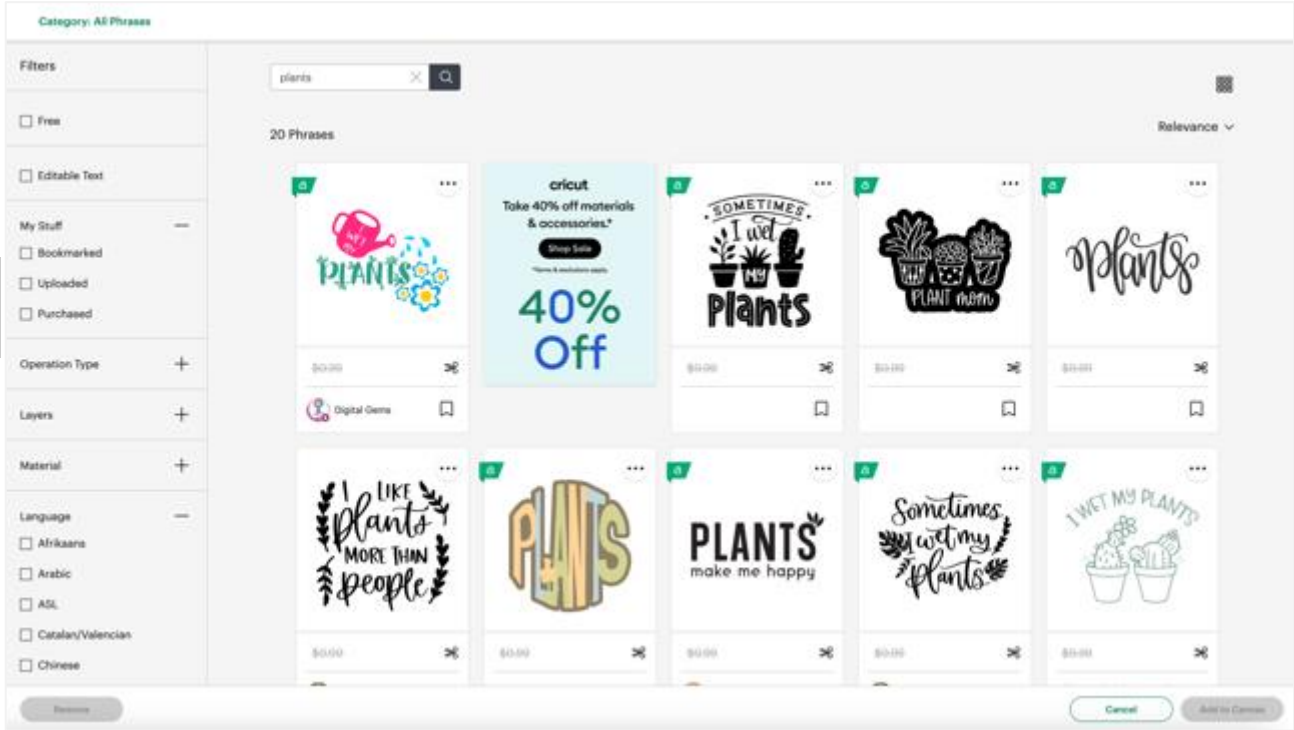

Editable Images are graphics with text fields that you can customize with your own text.

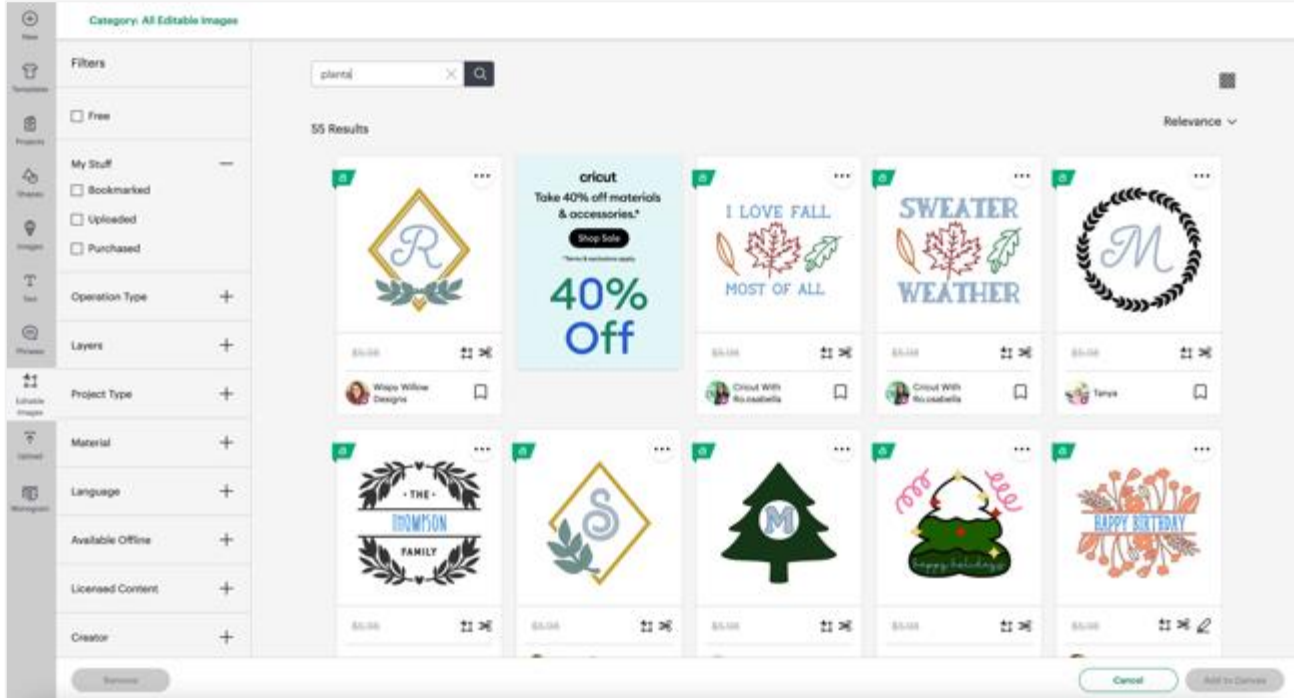

The upload icon allows you to upload your own images in compatible file types for truly personalized projects.

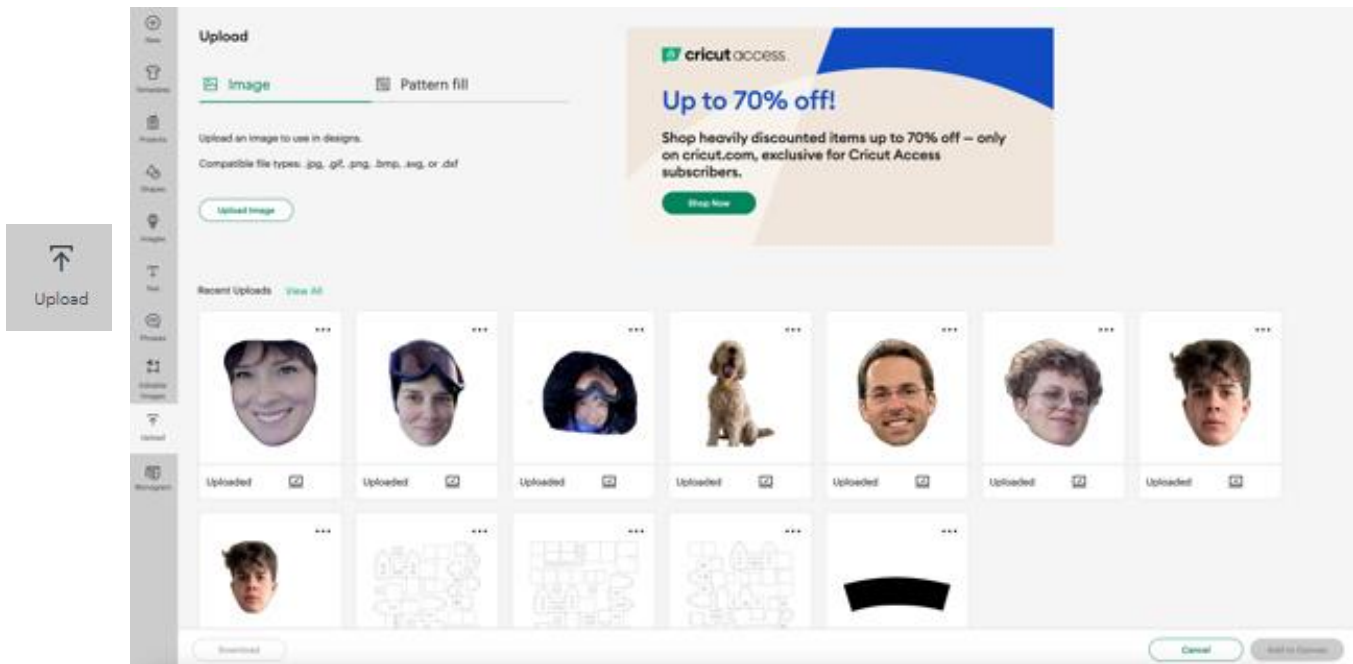

Monogram Maker has a variety of monogram layouts for you to personalize.

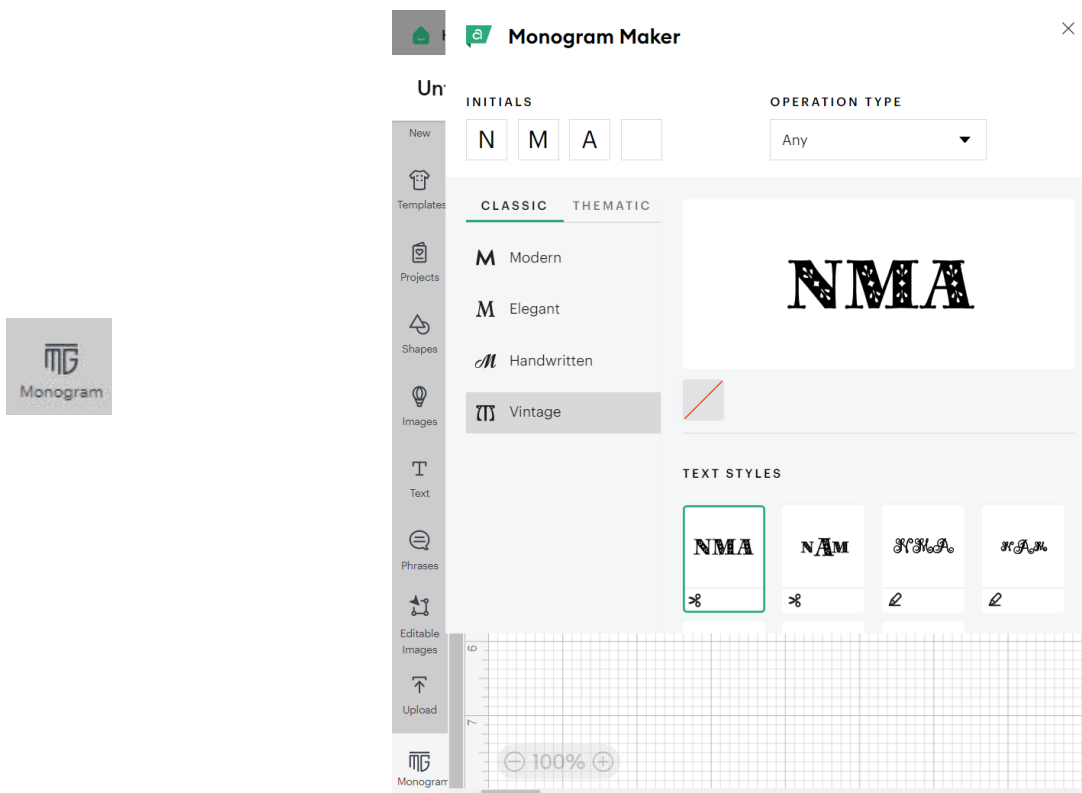

Let's take a closer look at the **Edit Bar** in the next section.

The Edit Bar -

The Canvas Edit Bar gives you many options for manipulating your design and will populate with different tools when you're working with different design elements.

Undo and redo offer an easy way to go back and forth a step in the design process.



Choose cut, draw, or guide options with this dropdown under **Operation**.

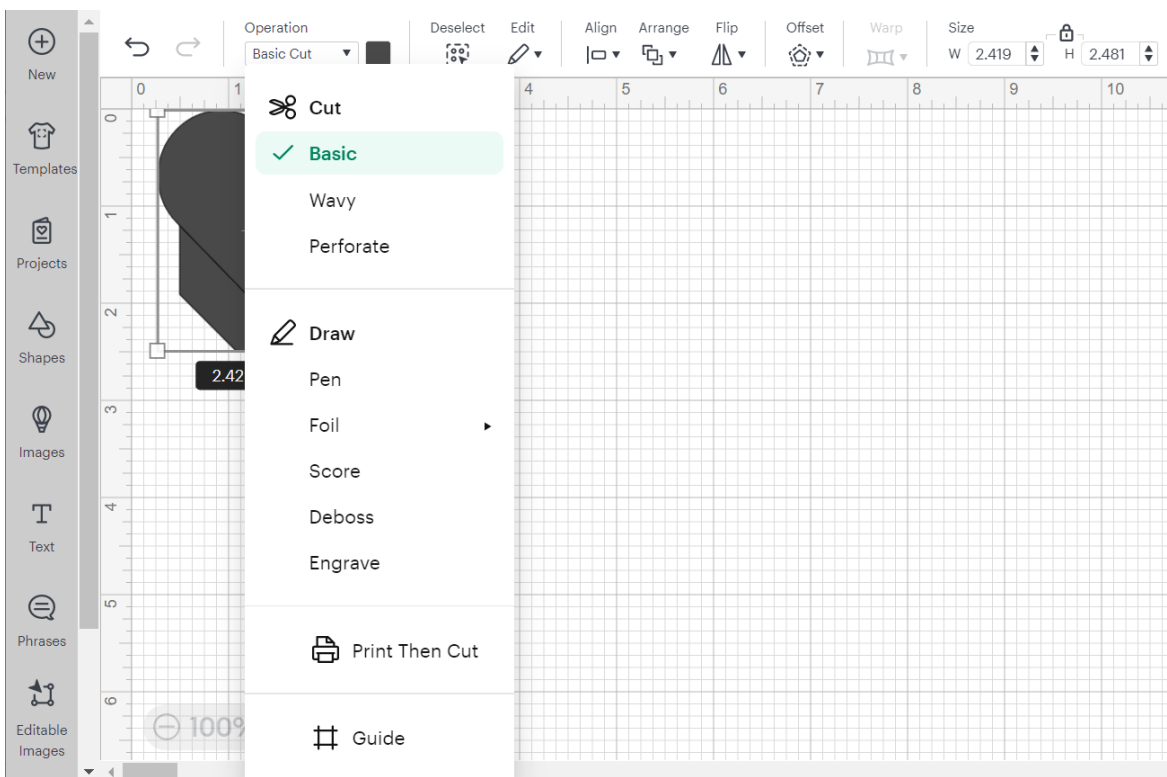

This box next to Operation allows you to choose or change the **color** of your material, pen or foil.

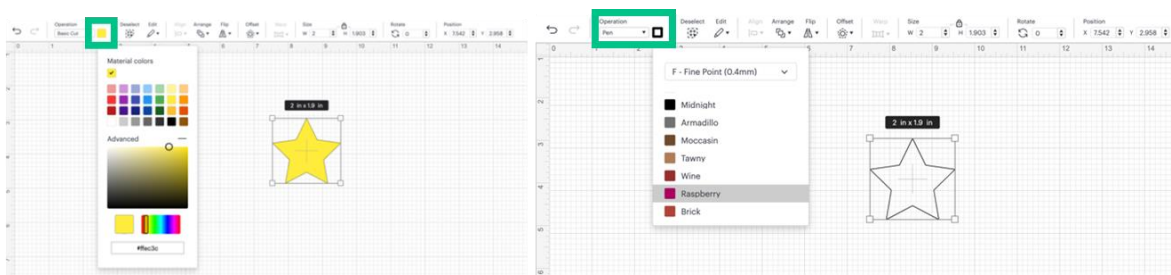

Select All selects all visible elements on your canvas together. When items are selected, the icon changes to **Deselect**

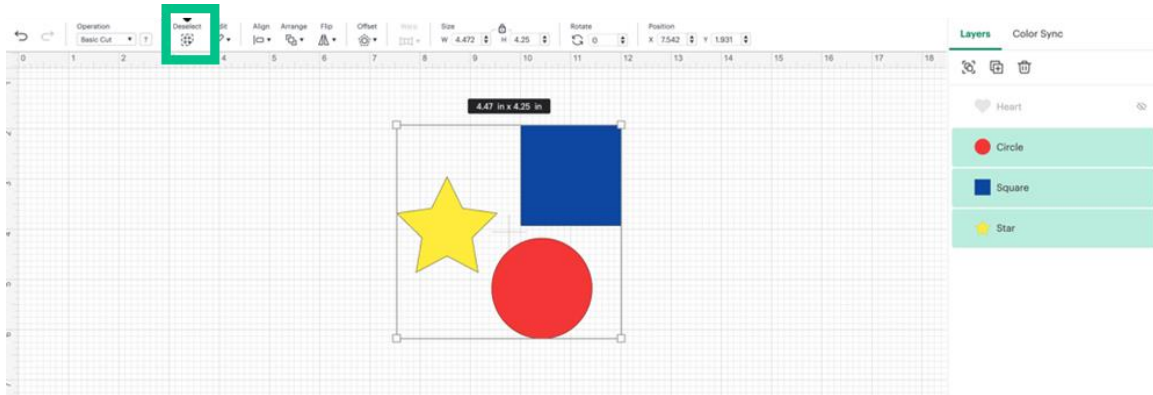

Cut, copy, paste, duplicate, or delete elements by clicking on the **Edit** icon.

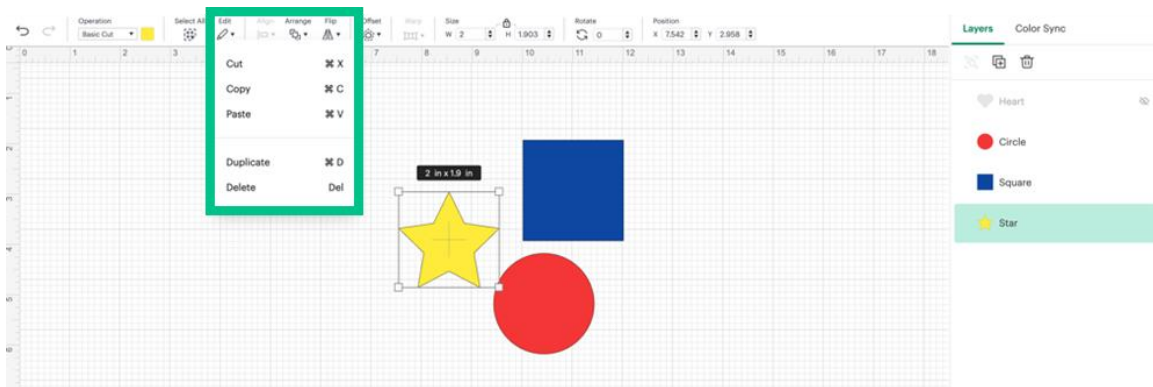

The **Align** dropdown helps to align or center multiple design elements.

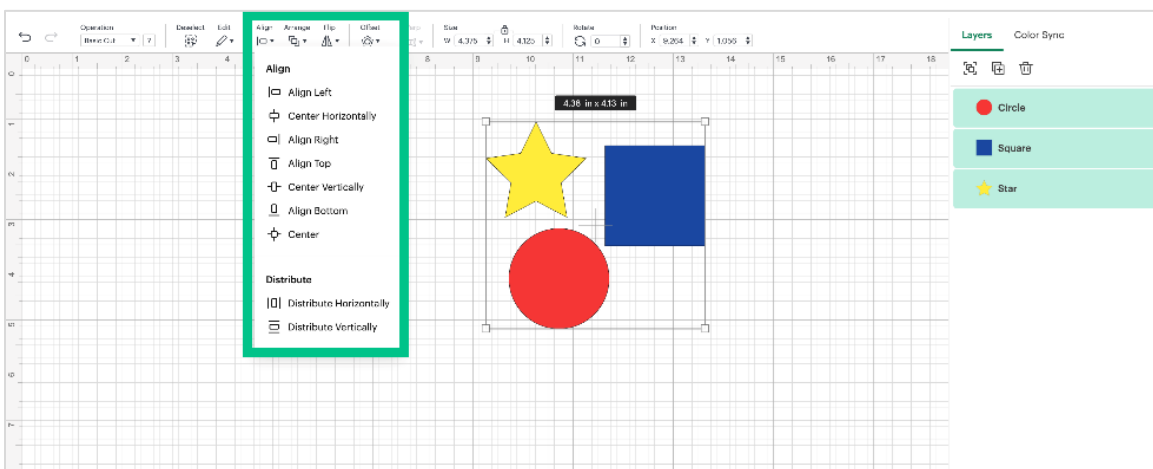

The **Arrange** panel can move layers to the front or back of the Canvas.

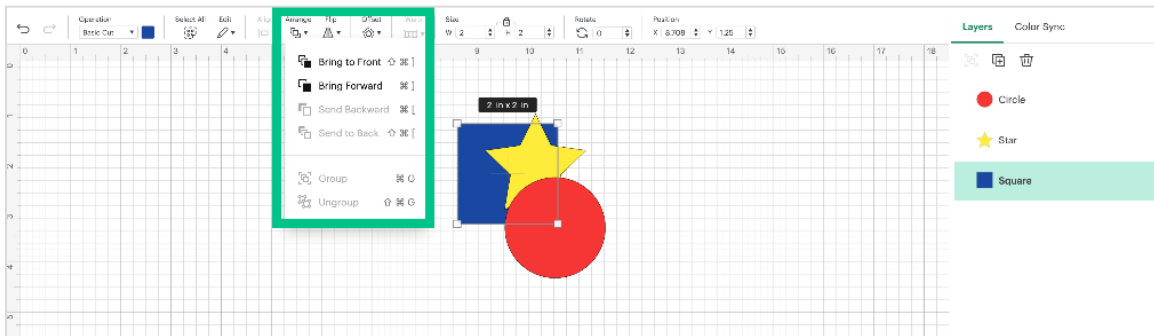

The **Flip** function allows you to flip an element horizontally or vertically.

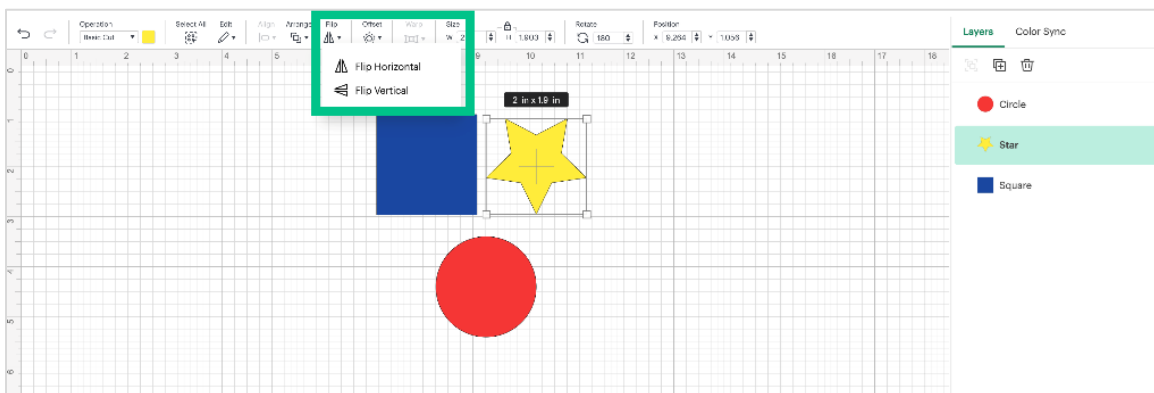

The **Offset** feature allows you to create a precise and repeatable border inside or outside of your design.

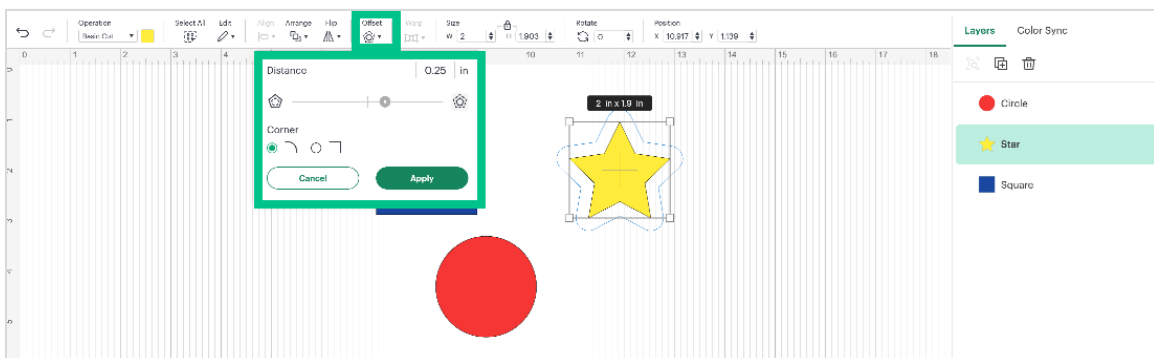

Warp is an editing tool specifically for text and allows you to warp your text in predesigned ways along a sliding scale. We will go over the text edit bar a bit more later.

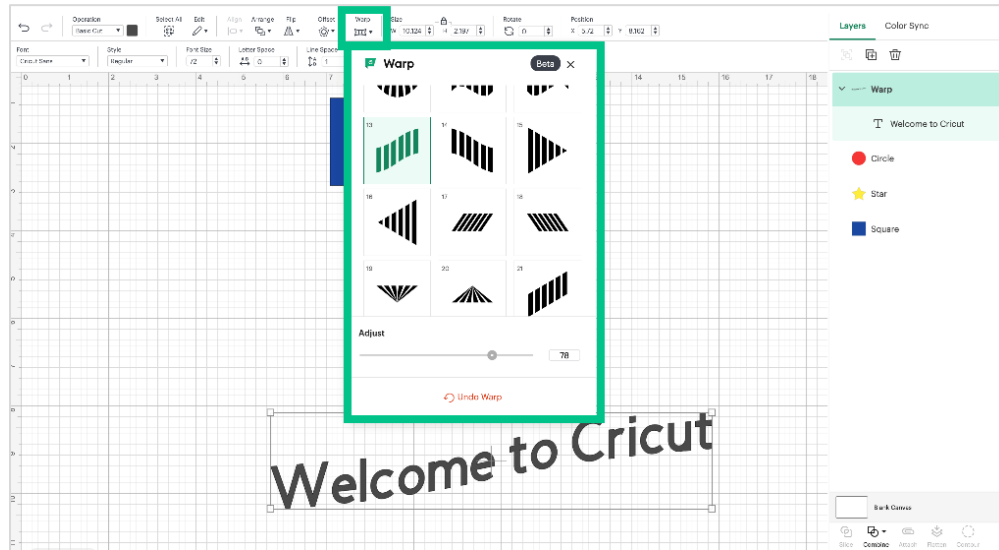

You can precisely change the width or height of your image under **Size**, keeping the proportions consistent, or you can change each dimension independently after opening the proportions lock.

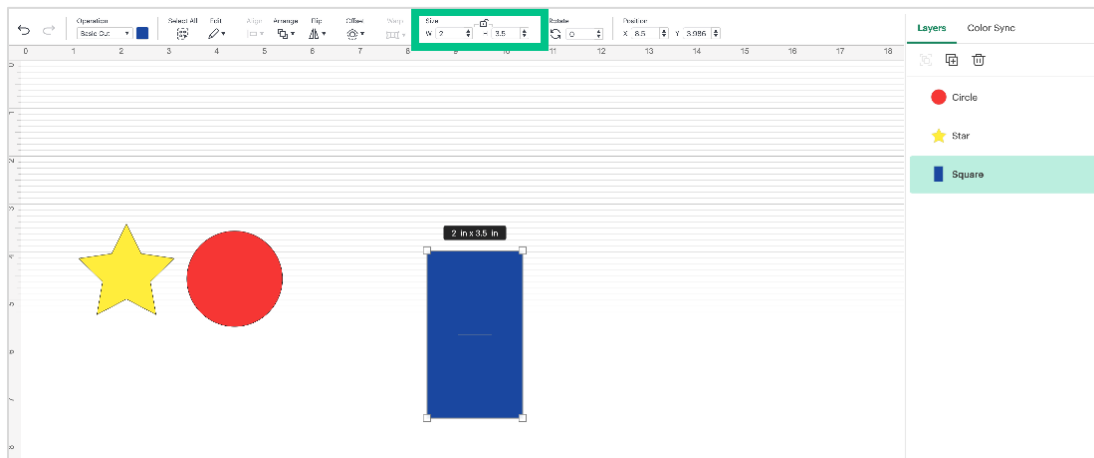

Use the **Rotate** function to precisely rotate images or text.

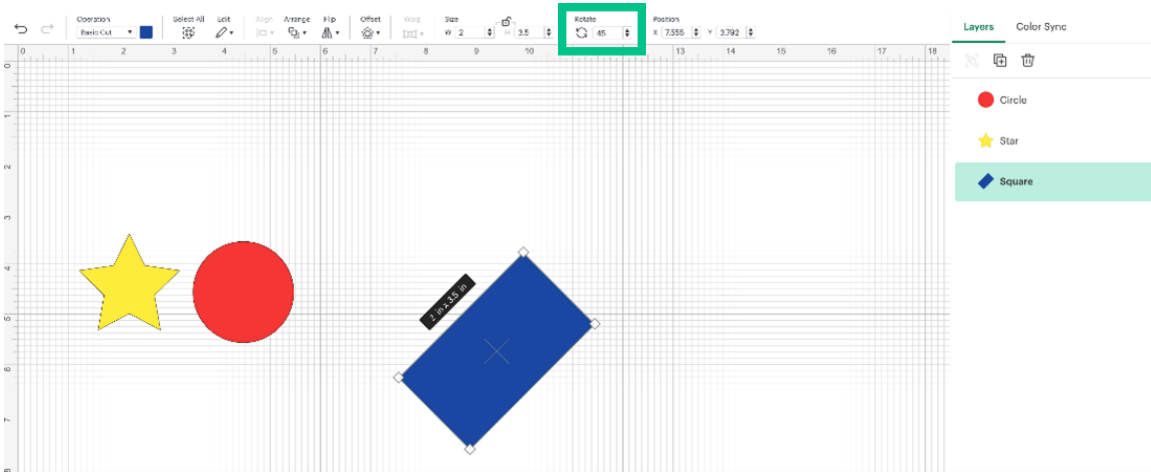

Position is useful for precisely lining up multiple elements on the X and Y axis.

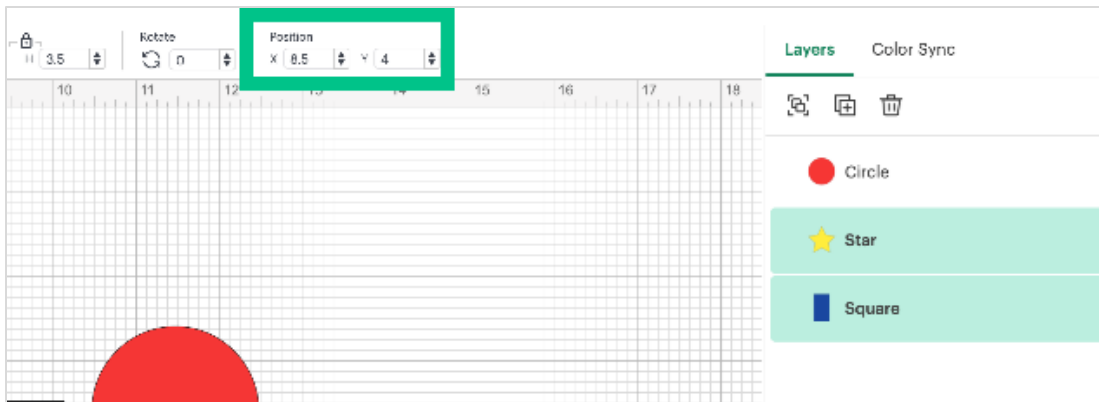

Many of these operations can be performed in different ways, such as hotkeys or right-clicking with your mouse. Additionally, there are handles around the design elements that you can use to drag your image to the size, shape, and proportions that you want.

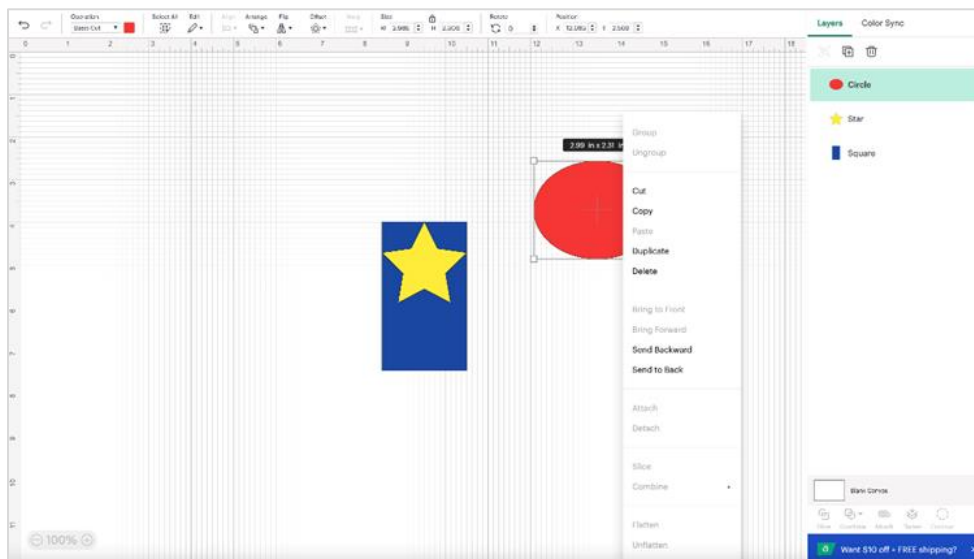

Text Edit Bar -

When working with text, you get an additional toolbar. It allows you to select fonts, style, size, spacing, and formatting.

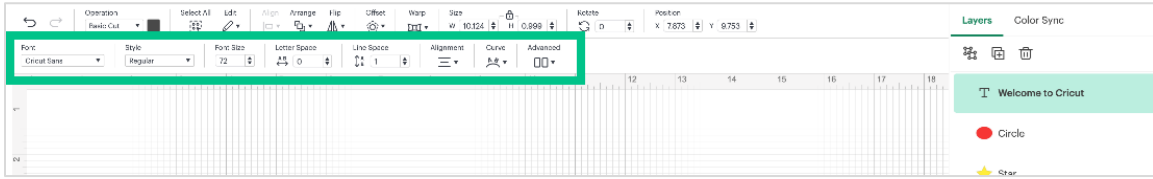

You can curve text that is only one line or use the **Warp** feature for even more fun possibilities.

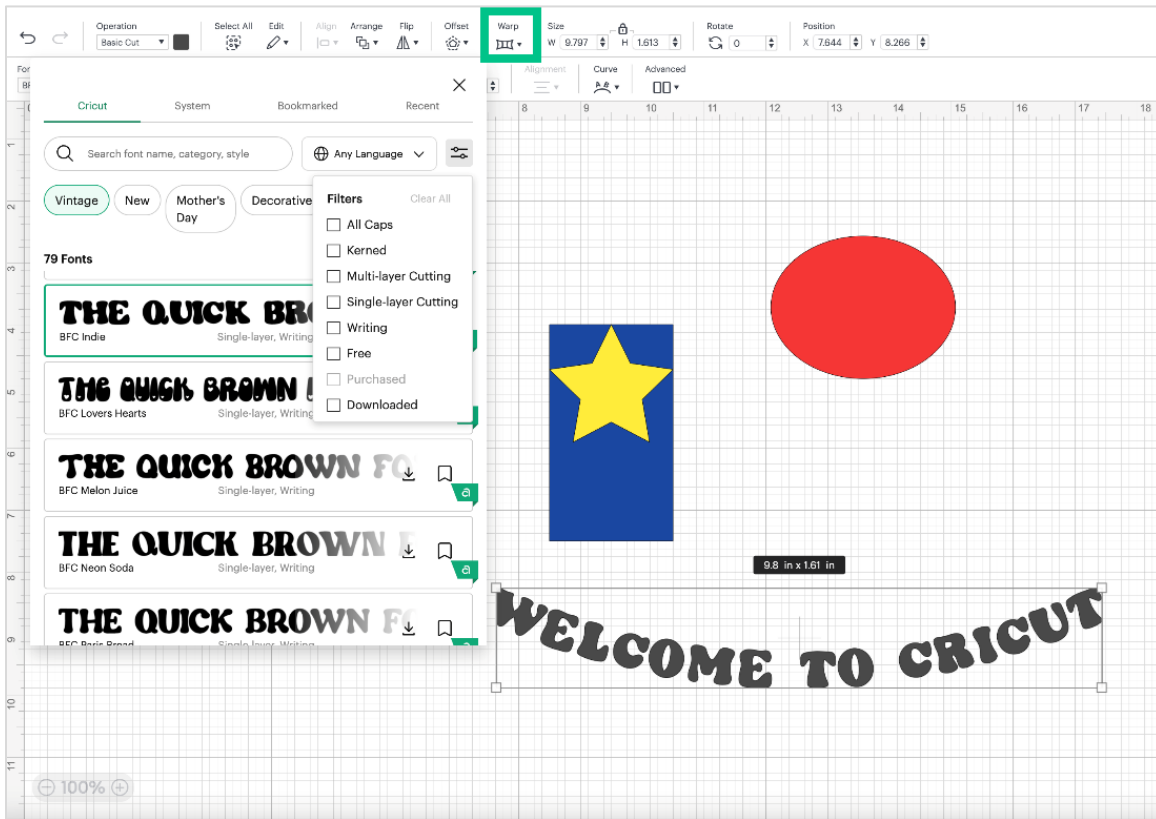

Advanced options will allow you to ungroup certain elements on your canvas.

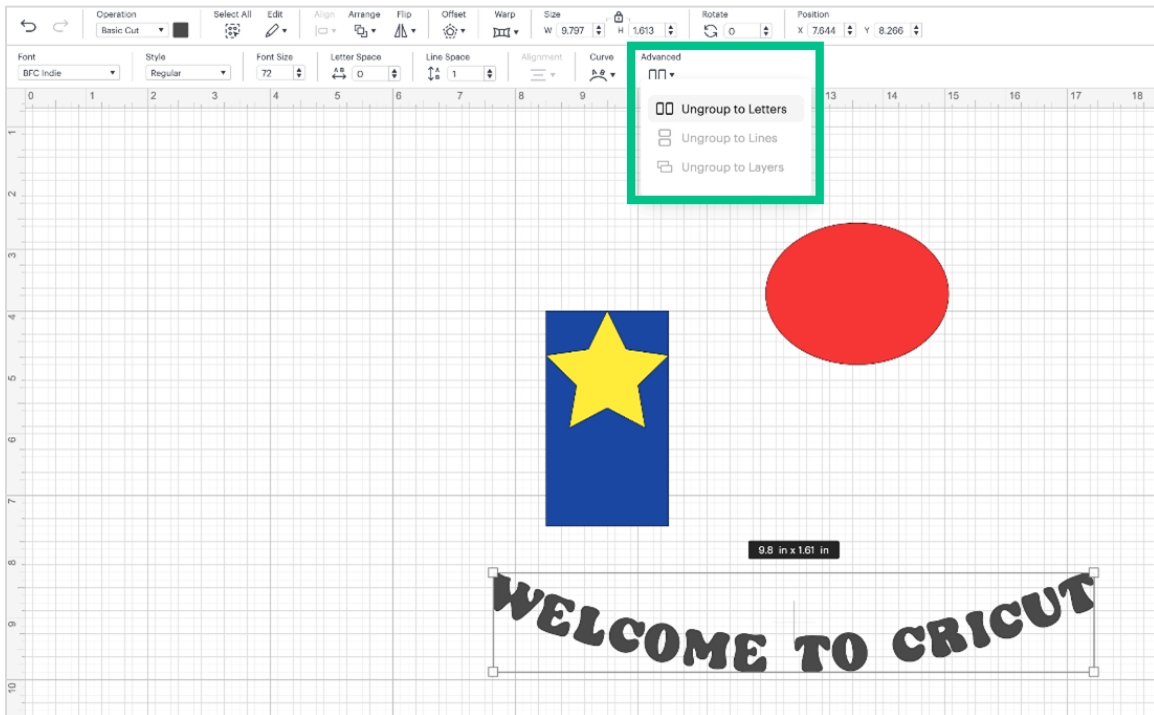

The Layers Panel -

The Layers Panel runs down on the right side of the Canvas. You'll use the layers panel to manage multiple images and or text on the Canvas.

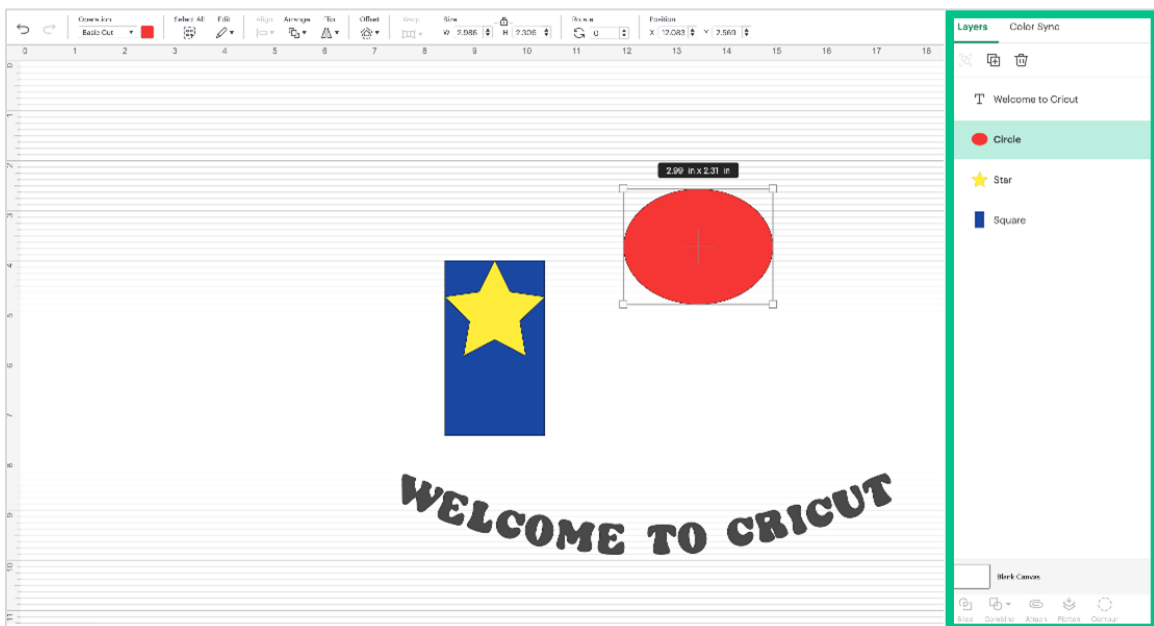

Each of your design elements will appear as a unique layer in this panel. To help with organization, you can rename as needed by double-clicking on the layer.

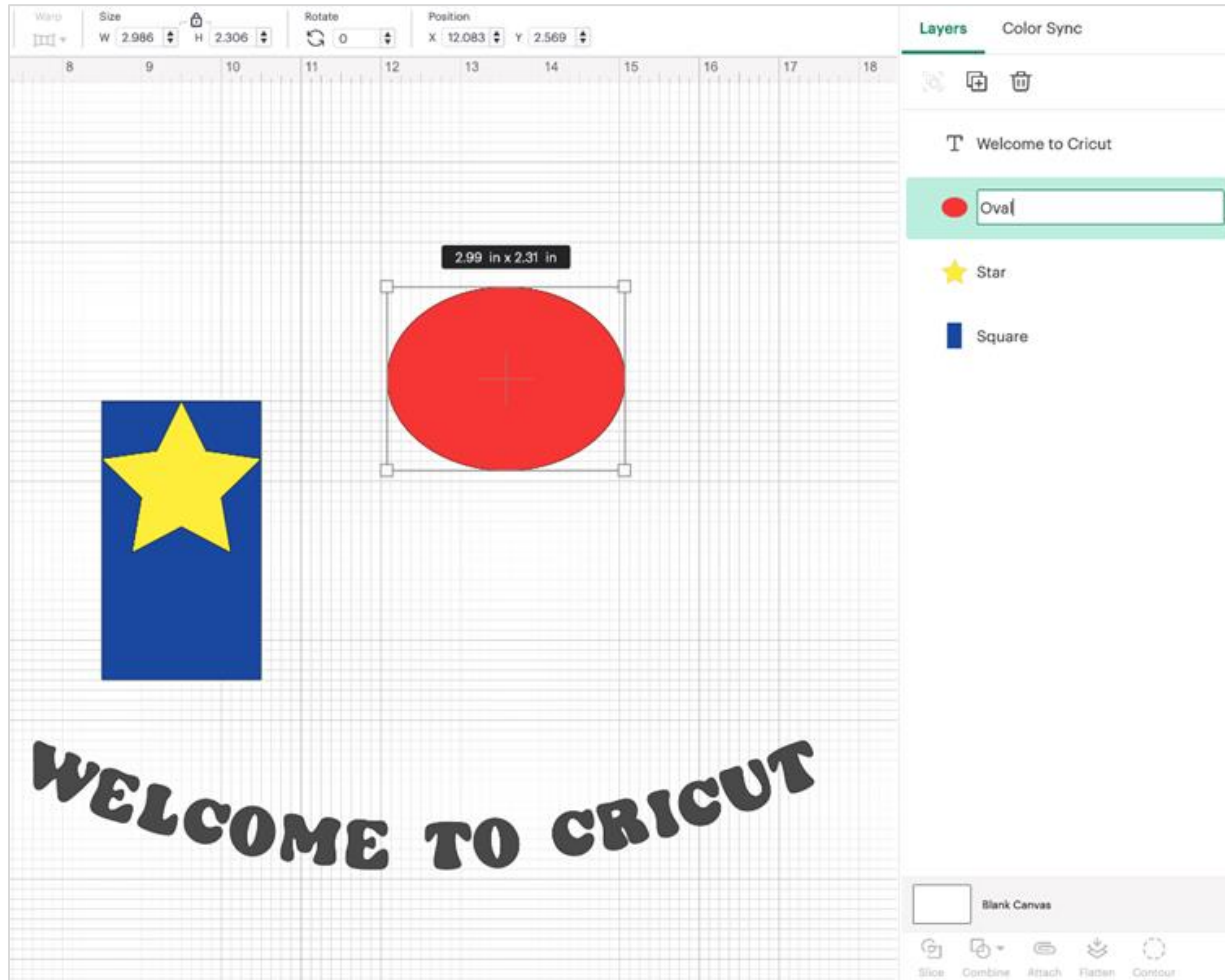

Once highlighted, you can group, ungroup, duplicate, or delete using the icons at the top of the panel.

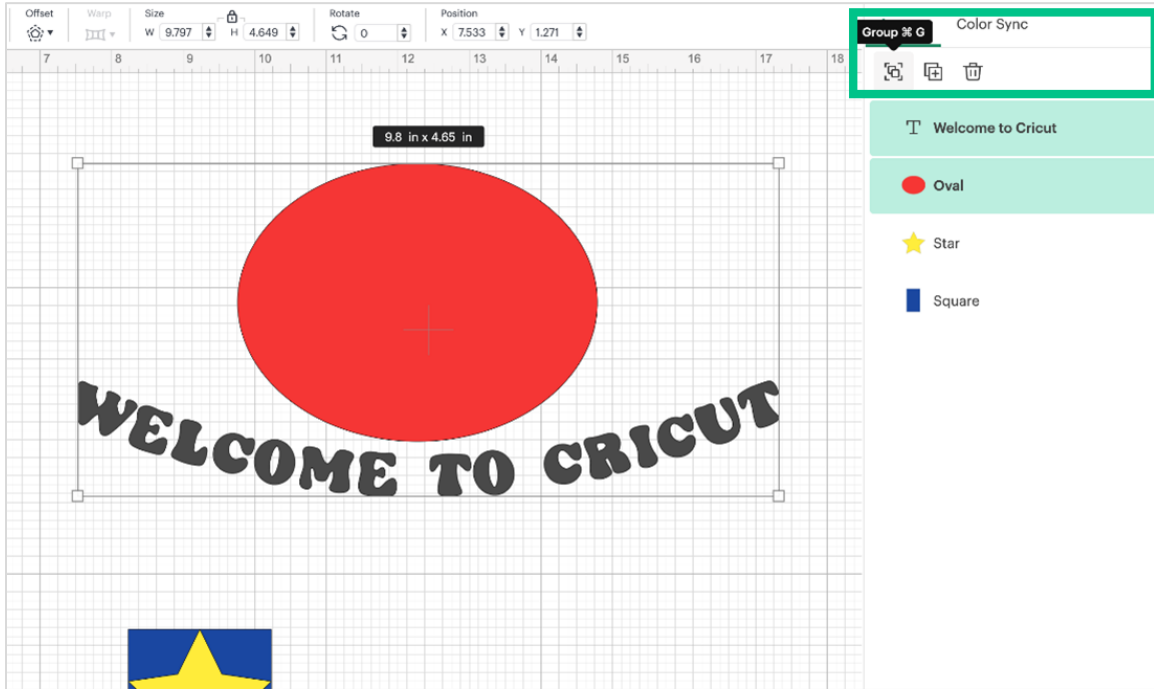

You can use the eye on the right side of each layer to hide that layer.

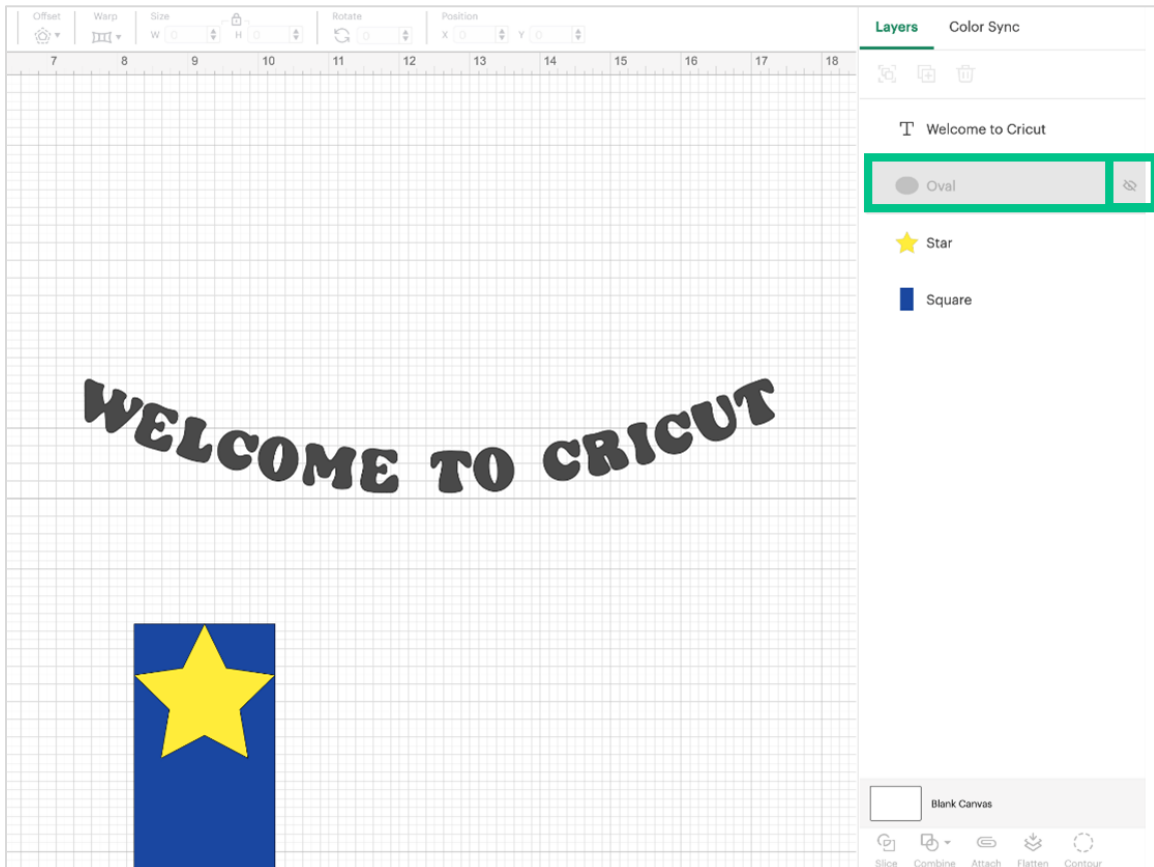

This can be useful if you aren't ready to delete a layer, need to adjust just one of the layers of an attached set, or want to only send part of your design to the cutting machine.

A red warning circle will appear if your design is incompatible with the cutting machine you've selected. For example, if a layer is too big for your machine.

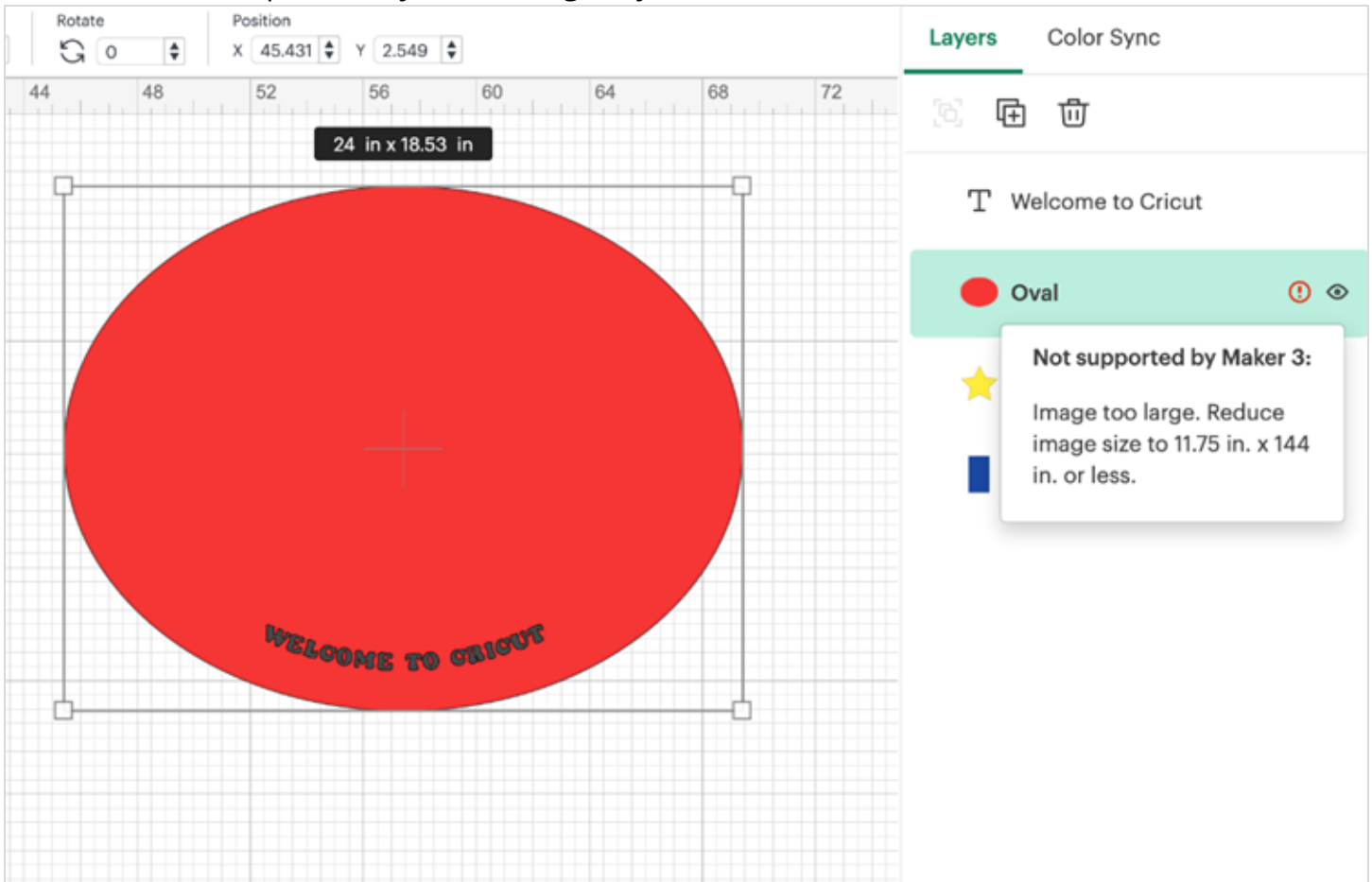

The bottom of the layers panel includes the powerful slice tool, the combine menu, attach, flatten and contour.

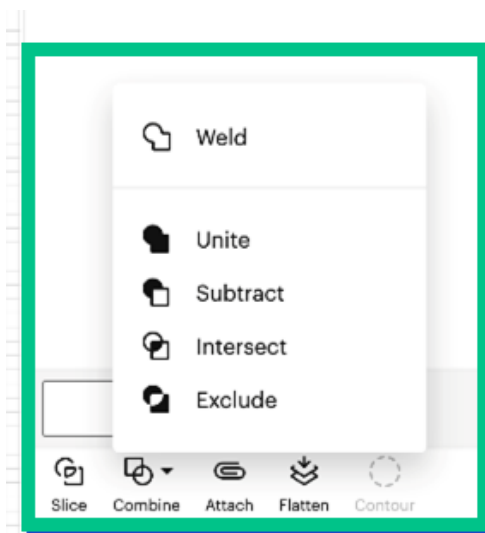

Once you've finished your design, **Save** it. **(1)**

Next, Design Space will guide you through the prepare and make process with simple step-by-step instructions.

A good tip is to follow the green button prompts to guide you to the next step.

Click the **Make It** button on the Canvas. **(2)**

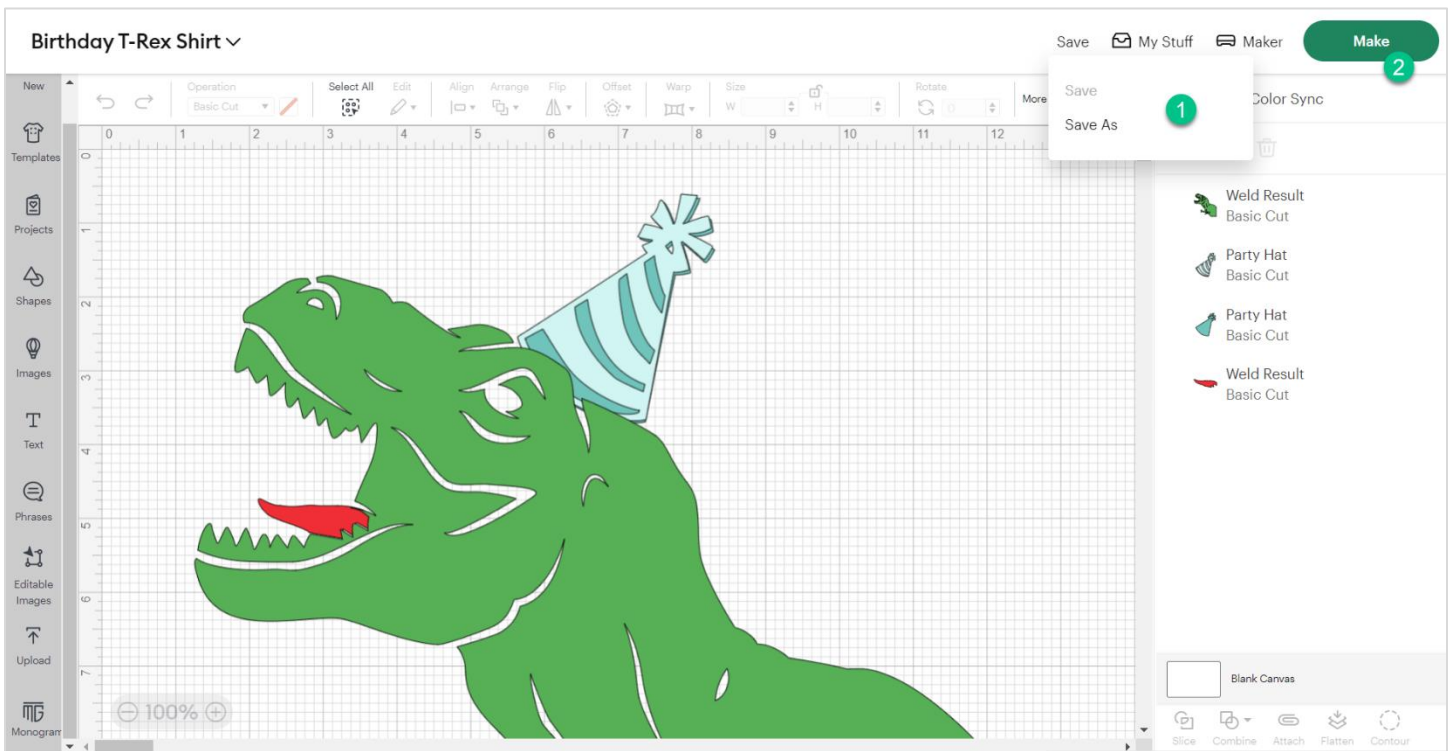

Note: On the Cricut Joy, Cricut Explore 3, and Cricut Maker 3 machines, you may first be asked to choose how you will load your material into your cutting machine (Smart Materials or on a mat).

Now, let's move on to the **Prepare Screen**.

The Prepare Screen -

The Prepare Screen is where you'll be working as you transition from designing on the Canvas to cutting or drawing with your Cricut machine.

At the top left on the Prepare Screen, you can choose how many copies you would like to make of the entire project. Click **Apply** to update the preview.

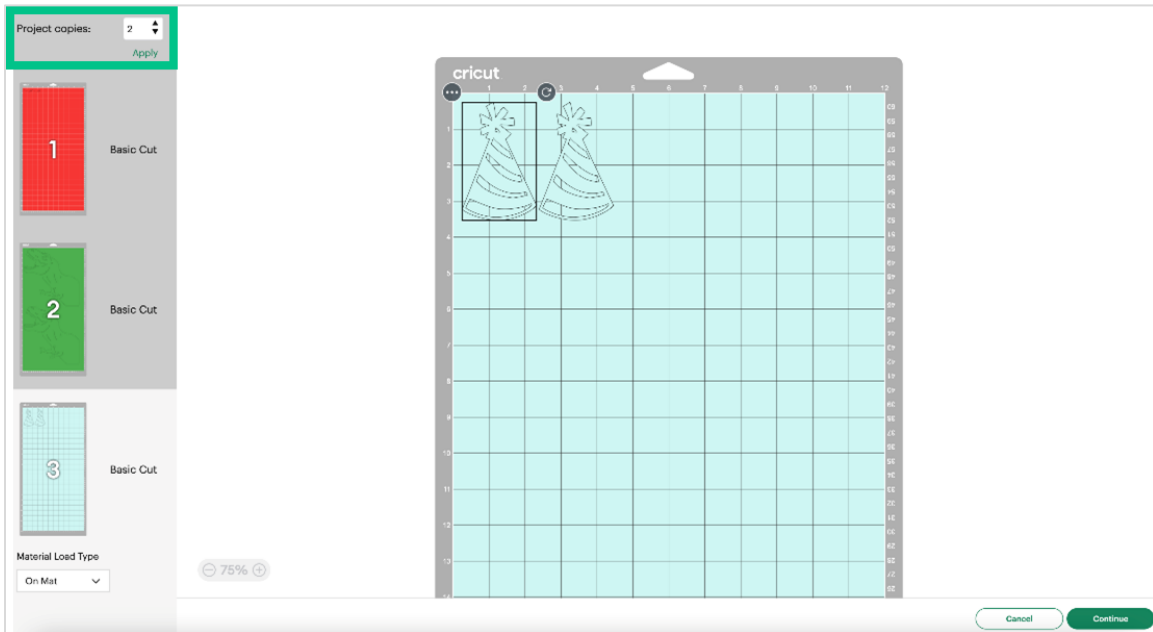

You can also choose your material size to ensure your design is lined up properly on the mat in the preview screen or to tell the machine you're using a larger mat.

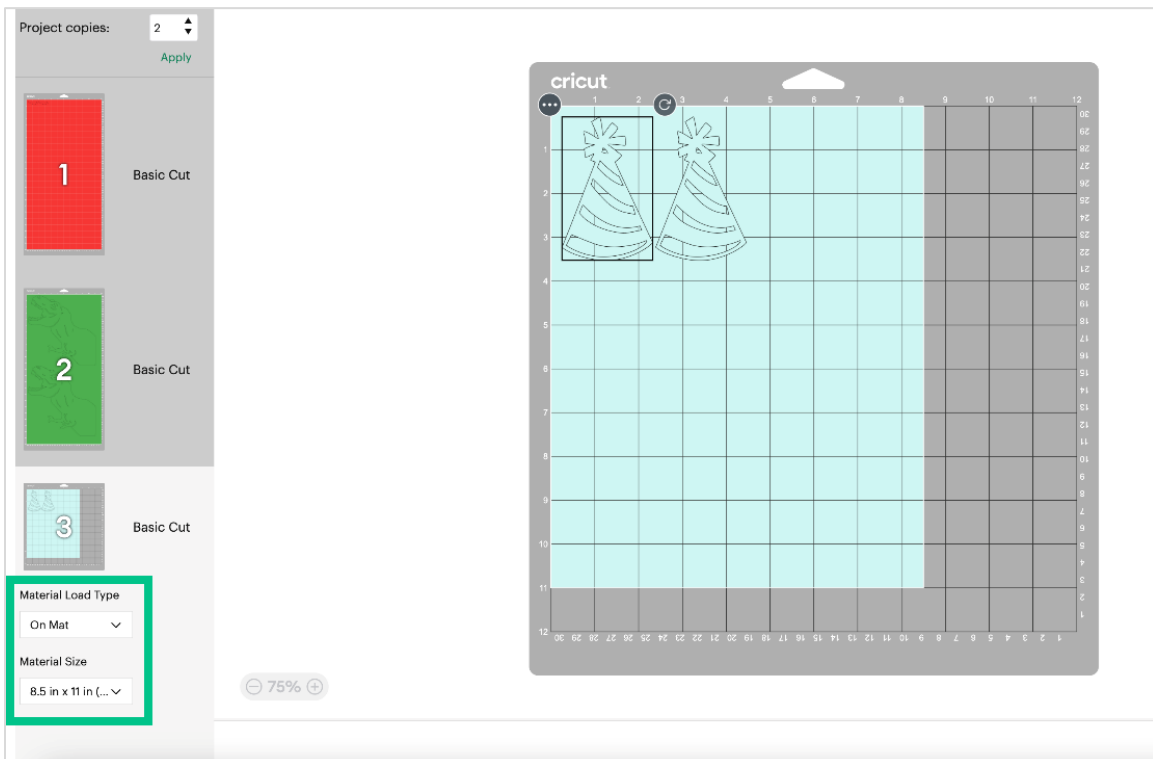

This is particularly important when using the Card Mat.

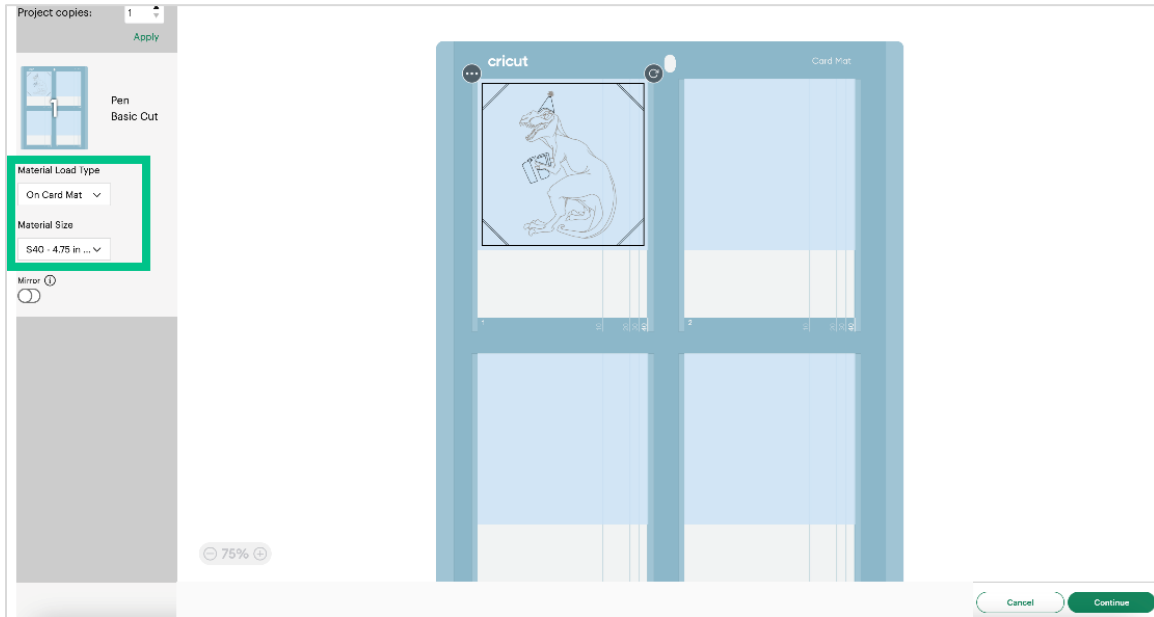

Don't forget to **mirror** if you're working with Iron-on or Infusible Ink and remember to put the shiny side of these materials face down on the mat.

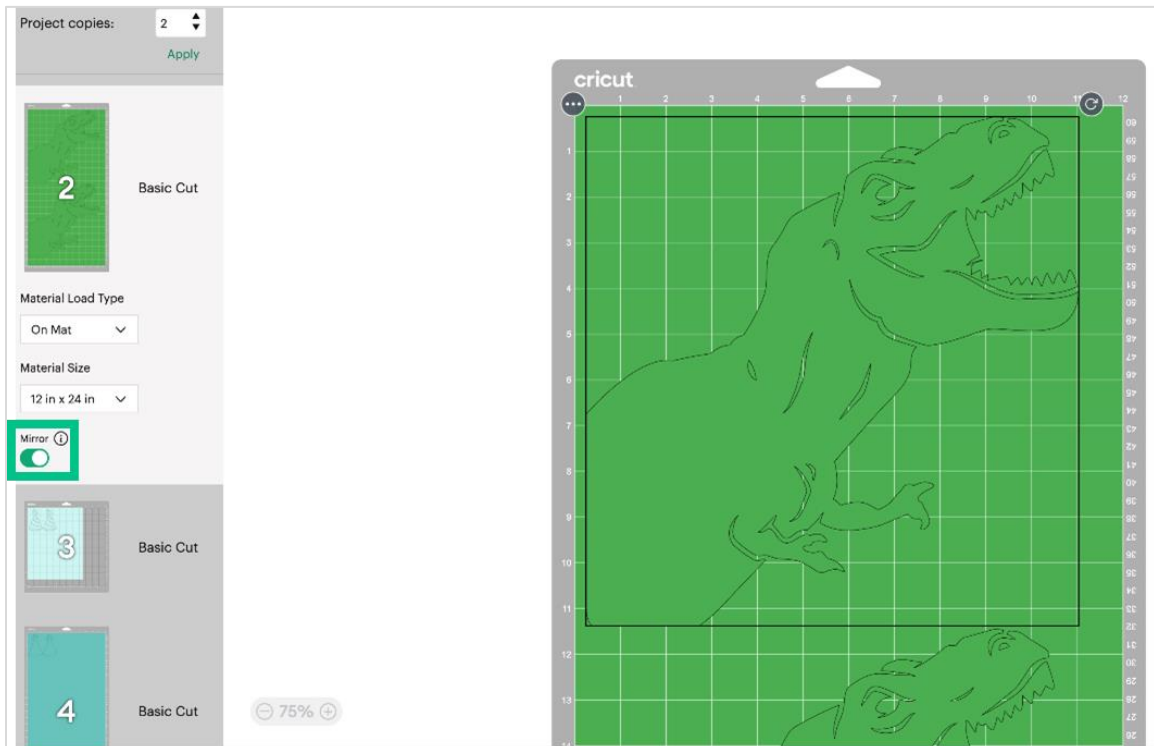

To save space, or if you're using scraps, you can move your design around on the preview portion of the screen, using the grid lines to match the grid on your mat.

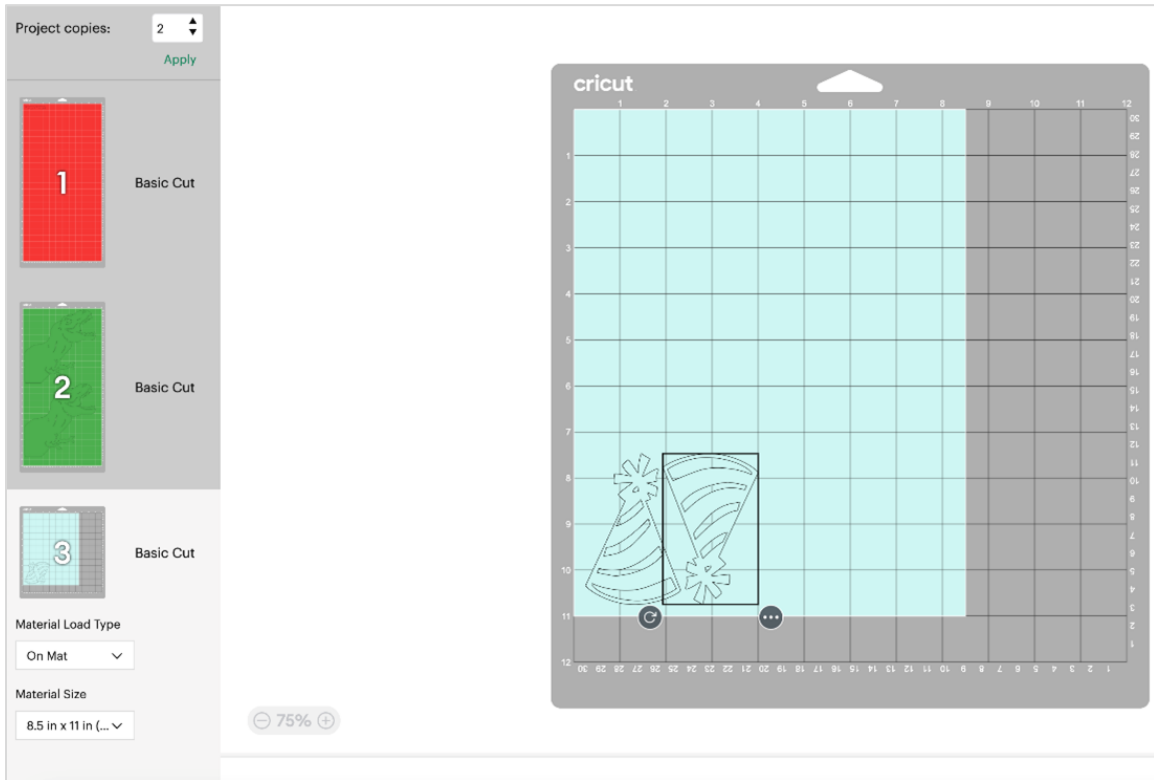

Select **Continue** to move on to the **Make Screen**.

The Make Screen -

The Make Screen is where you will select the material you'll be cutting once you've connected to your machine.

Select **Browse All Materials** to select the specific material you are using. You can bookmark up to 12 favorite materials.

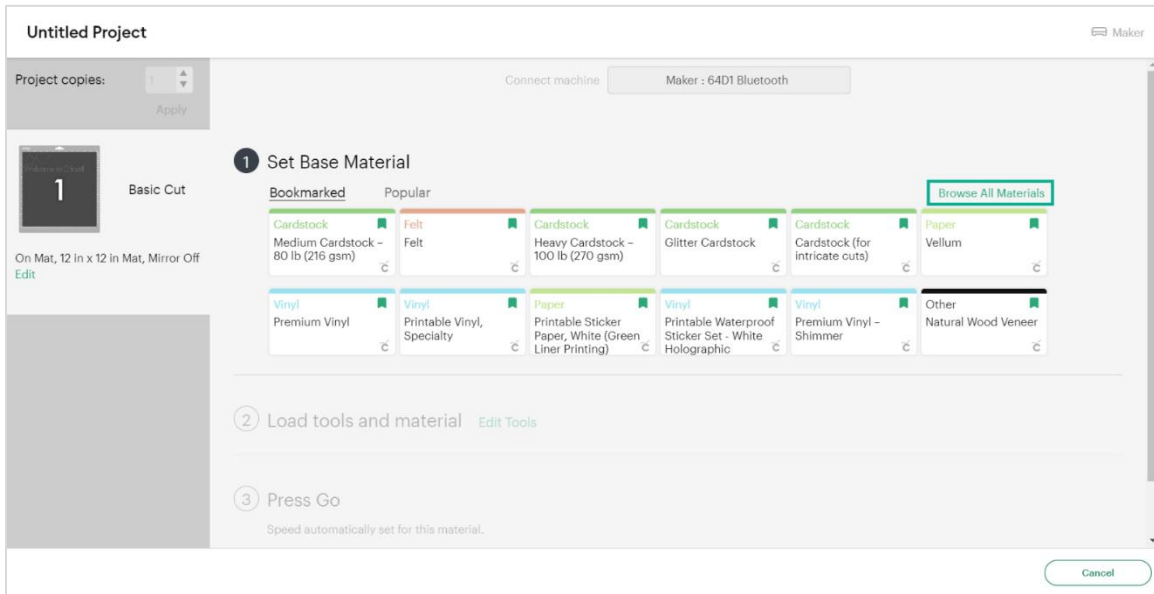

You'll be shown an overview of which tools you'll need for your project.

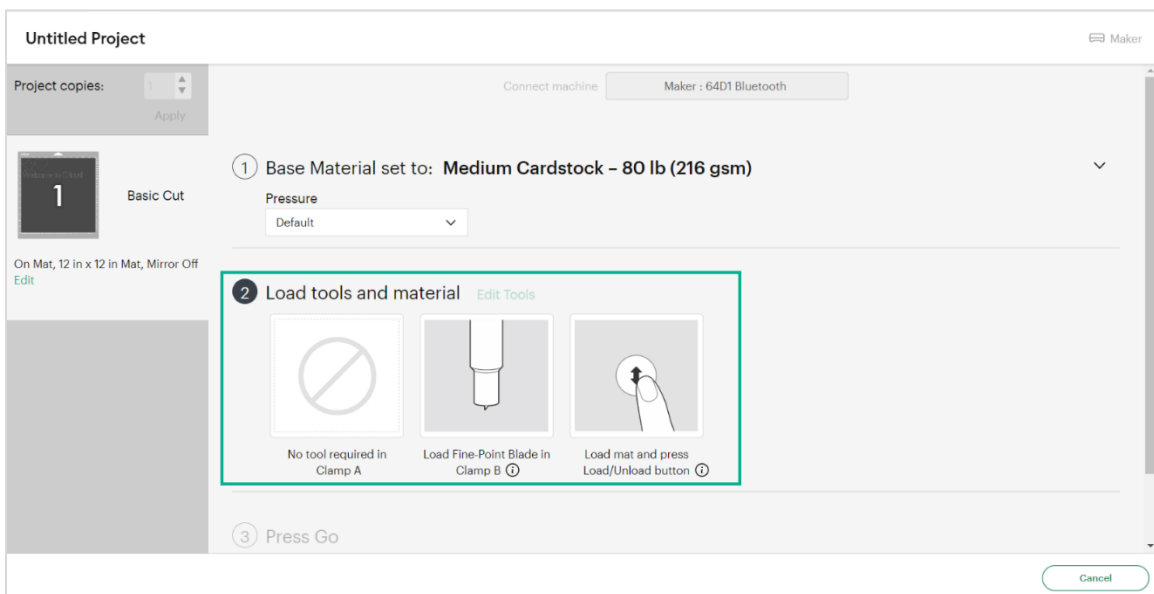

That's it. You are all ready to cut or draw your design. Now load your mat and press Go!

Come back anytime you need a Design Space refresher.

We can't wait to see what you create!